

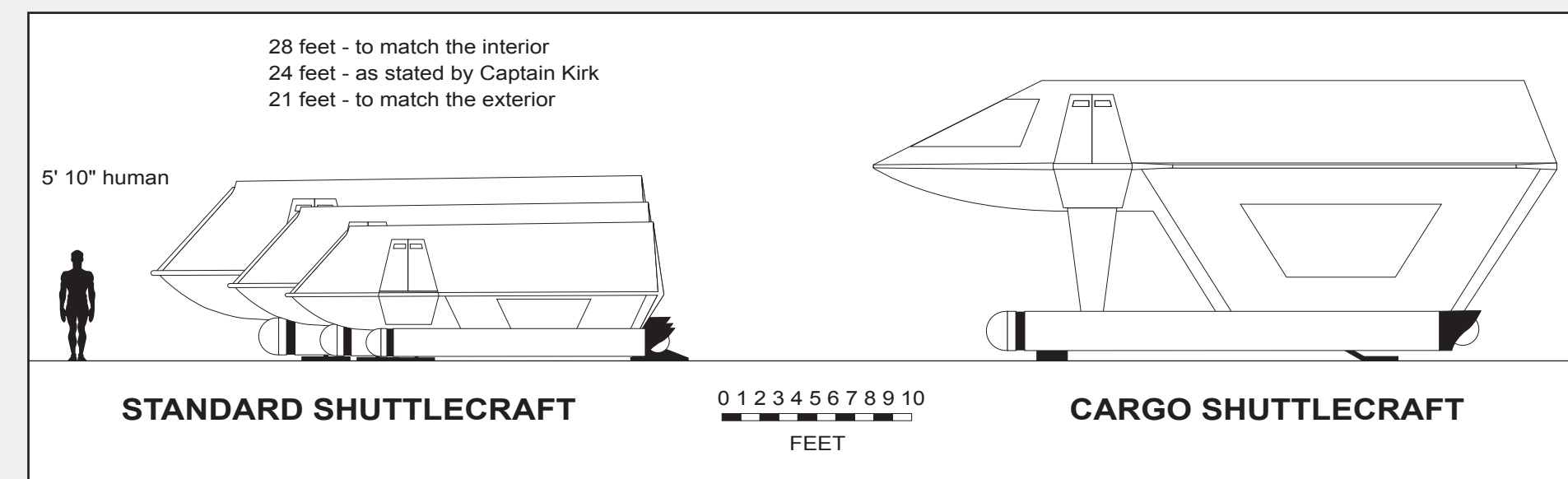

- 1
- 2
- 3
- 4
- 5
- 6
- 7
- 8
- 9
- 10
- 11
- 12

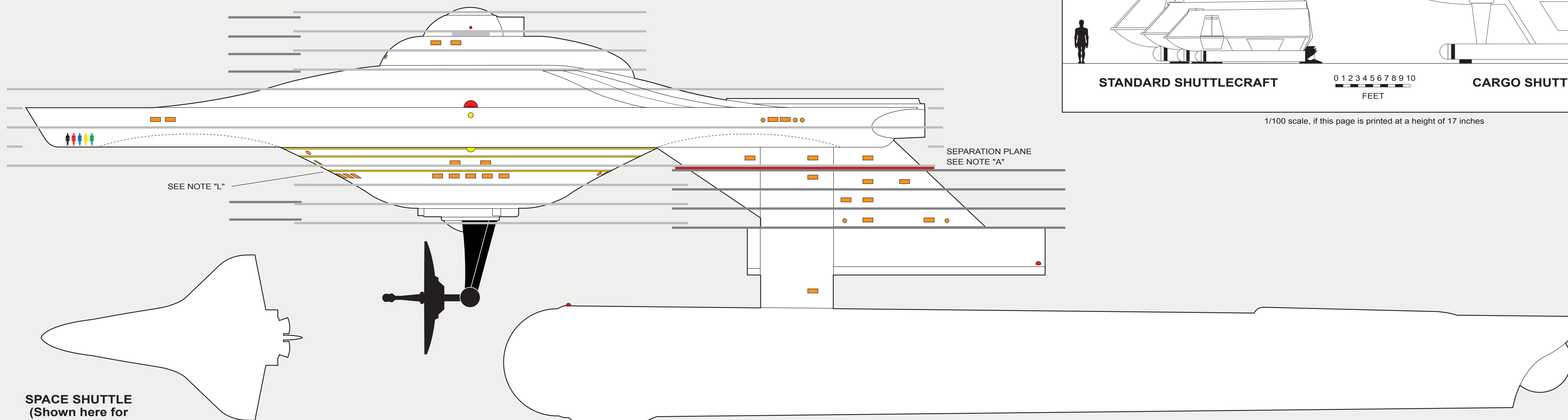

1/100 scale, if this page is printed at a height of 17 inches

## BACKGROUND HISTORY

This project is an extrapolation of the U.S.S. ENTERPRISE drawings developed earlier this year. Those drawings were governed by 3 criteria:

- (1) The 11-foot-2.08-inch (3.4-meter) studio model,
- (2) The Writer's Guide, and
- (3) The 79 episodes plus the original pilot.

There are no such criteria to guide these drawings, but the basic design philosophy is to complete the ships Franz Joseph (FJ) developed for his Technical Manual in the same style as his Heavy Cruiser blueprints. The goal is to try and fit all the components inside the hull. But what are "all the components"? What are the roles of "Tugs" and "Transports" in the STAR TREK universe?

Historically, a "Transport" was a type of ship used especially for taking soldiers or military supplies from one place to another.

A "Tugboat" or "Tug" was a type of vessel that maneuvered other vessels by pushing them with direct contact or pulling them with a tow line. The vessels being moved are restricted (for one reason or another) in their ability to maneuver on their own. Tugboats are powerful for their size and strongly built.

In Starfleet, a "Transport" ship has a limited role, similar in function to a shuttle (but much larger) designed to carry people or supplies. The Federation separates "Transport" ships into two categories: commercial and non-commercial.

A "Tug" (or towing vessel) is a starship specialized for towing other starships or similarly large objects with tractor beams.

The Transport / Tug is basically a cargo ship, and as such, it does not deviate from established routes. With a properly configured cargo container, these ships have a longer duration (time-wise) than many other classes. However, they are not heavily armed. Should these ships ever be attacked, they have only two Phaser Banks. The ships have an energy surplus which can be directed to deflectors and shields. It is this energy surplus which led to the Surya-class and Avenger-class designs.

This layout retains the lines as established by Franz Joseph. It could be argued that the Hangar Bay doors are not visible in the FJ drawings because their outlines follow the Deflector Grid lines. This FJ design appeared in the movies on various displays on the Bridge of the U.S.S. ENTERPRISE.

## NOTES

As with my Heavy Cruiser plans, I started at the edge of the primary hull (see image below), where the height of 2 decks, the thickness of 1 floor, and the thickness of 2 hulls have to fit in this part of the saucer.

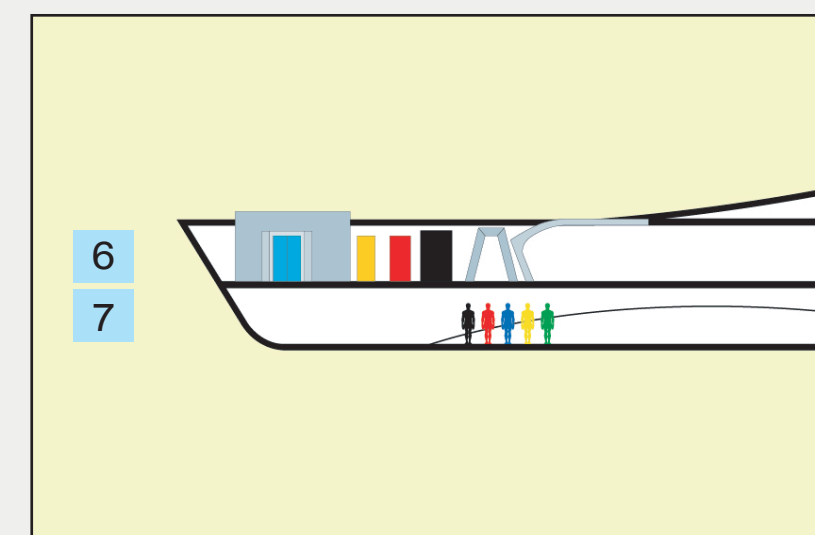

In CHARLIE X we saw how thick the walls are and also what is in the walls. The DESILU plans show walls that are 1 foot (0.3 meters) thick and sometimes even thicker. I decided to make all walls, decks, and hulls 1 foot thick, never thinner. In a few places, the walls are even thicker.

This leaves a ceiling height of 8 feet (2.44 meters) for each level.

The one set piece (reminiscent of a ship's rib - often seen in the Briefing Room) does not quite fit. However, all the other details (doors, openings, etc) do fit (see image at left). I consider the trapezoidal openings to be Isolation Doors ... in case of hull breaches, damage control, intruder alerts, etc.

In the profile drawing (at the top of this page) the light grey horizontal lines show the initial deck locations. They represent a constant 8 foot ceiling throughout the entire ship.

I built them upwards and downwards from my starting point, Deck 6 and 7. However, this makes the Bridge too high, and Deck 11 too low. The dark grey horizontal lines show the adjusted deck locations. The resultant space between Dorsal Deck 8 and Dorsal Deck 9 becomes the "Separation Plane". On Constitution-Class ships this space is where I placed the Rear Landing Leg. The two triangular patterns on the underside of the Primary Hull are the Front Landing Legs, but on this class of ship, they were removed and egress hatches were installed.

Since disconnection equipment is located on Dorsal Deck 8 and Dorsal Deck 9, it makes sense to keep this area clear of crew and difficult to access except by authorized personnel. Therefore, these 2 decks are accessible only by ladders. Disconnection equipment is also located in each engine pylon.

## GENERAL NOTES

Are the wide steps in Engineering considered to be "stairs"? Are the steps on the Bridge considered to be "stairs"? Perhaps stairs do not appear in any episodes, but that does not mean they do not exist in Starfleet ships. Therefore:

1. After engine nacelle disconnection and an emergency landing, stairs on Decks 4, 3, and 2 lead up to the hatch, thus allowing the crew to leave the ship quickly.
2. Each of the 2 Recreation Rooms on Deck 7 have balconies on Deck 6. Those balconies have stairs that lead down to their respective Recreation Rooms.
3. The two Cargo Operations areas on Deck 7 have wide stairs as well as cargo lifts.
4. Stairs connect the two levels of the Deflector Equipment at the front of the hull.

Aside from these stairs, the rectangular ladders (within rectangular alcoves) and the triangular ladders (within circular alcoves) supplement the turbo-elevator system. If that system fails, or in some other emergency, ladders alone would not be very efficient; it is easier to carry something up stairs than up a ladder.

There are external features that do not need to be marked: hatches for the Phasers, hatches for the Photon Torpedo Launchers, and the Primary Hull / Warp Engine disconnection line, to name a few. These drawings attempt to make sense of the markings that ARE visible on the studio model of the ENTERPRISE, all of which is then extrapolated onto the Transport / Tug.

More notes relevant to each deck appear on the following pages.

Contradictions and errors exist within the episodes. I am sure 100% continuity is not possible.

I hope these pages provide you with some pleasure, information, and ideas for contemplation / consideration.

If I missed something, please let me know.