



NOTES

REPAIR FACILITIES

Everything is duplicated (port and starboard); theoretically, 2 beacons or buoys can be processed at the same time.

DECK 8

Components for most types of beacons and buoys are stored on this deck.

DECK 9

Machine shops are located here for fabricating parts needed to repair the beacons or buoys.

DECK 10

Once the beacons or buoys are retrieved, initial diagnostics are performed on this level. Oversized doors allow transfer of equipment and materials from the port facilities to the starboard facilities.

DECK 11

This deck is not very tall. Fuel for the Navigational Beacons and Buoys is stored here.

At the extreme aft is the machinery for operating the Hangar Bay doors.

DECK 9

Most of the front half of this deck is unchanged from the original configuration of the Constitution-class ship. Material Reclamation and Fabrication is probably not a 100% efficient process. Therefore, these 2 hatches could allow for transfer of rare elements required in various manufacturing processes.

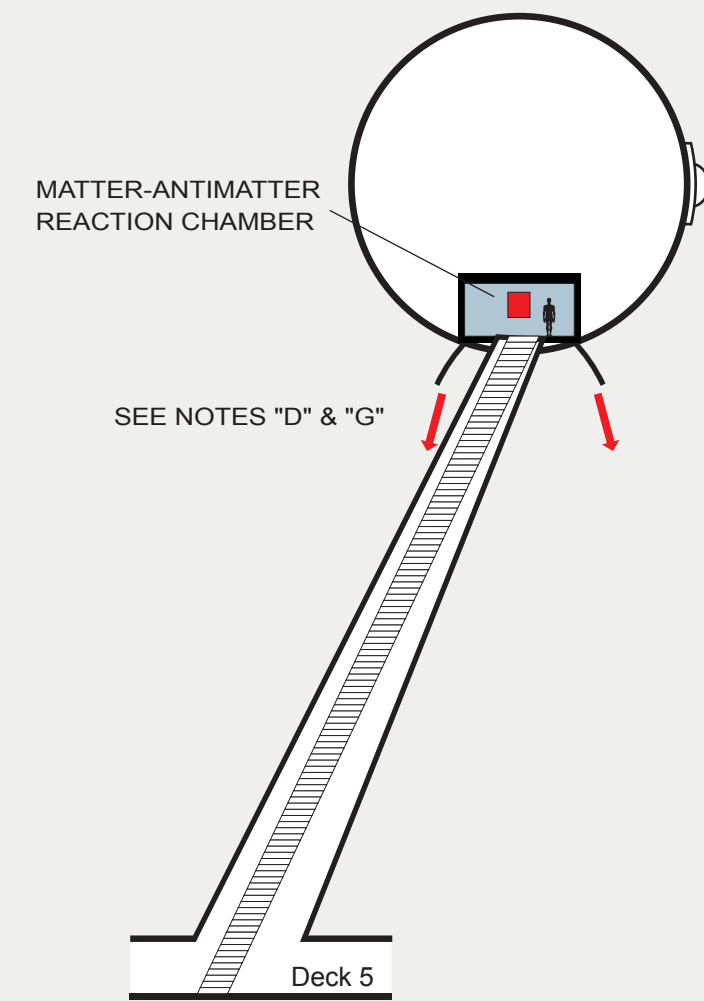

STARBOARD ENGINE INSPECTION STATION (Cross-section, Looking Aft)

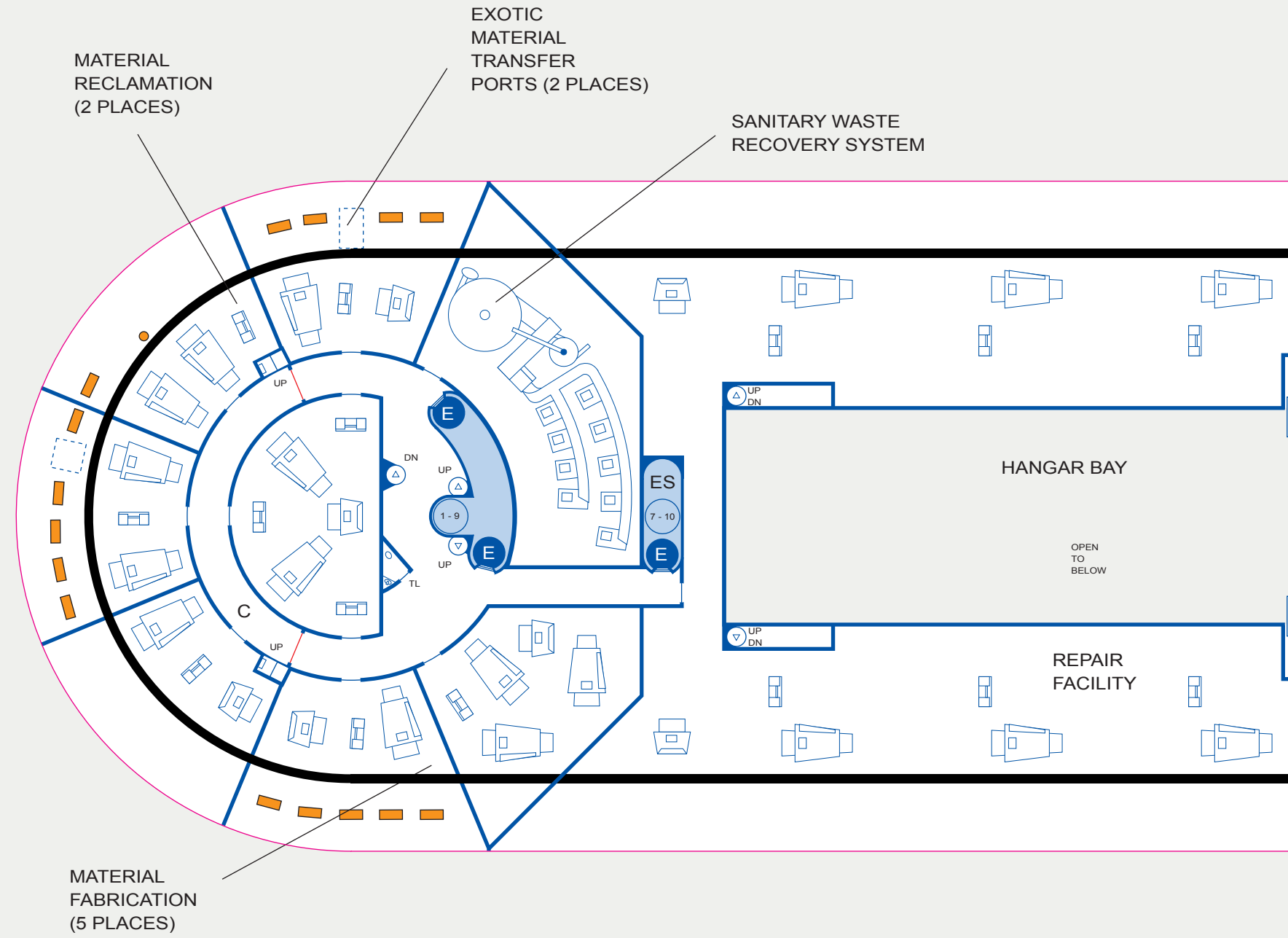

DECK 9: FABRICATION FACILITIES / HANGAR BAY