

# STAR FLEET

## STARSHIP RECOGNITION MANUAL

*REPORT:*

*DURANCE TRANSPORT*

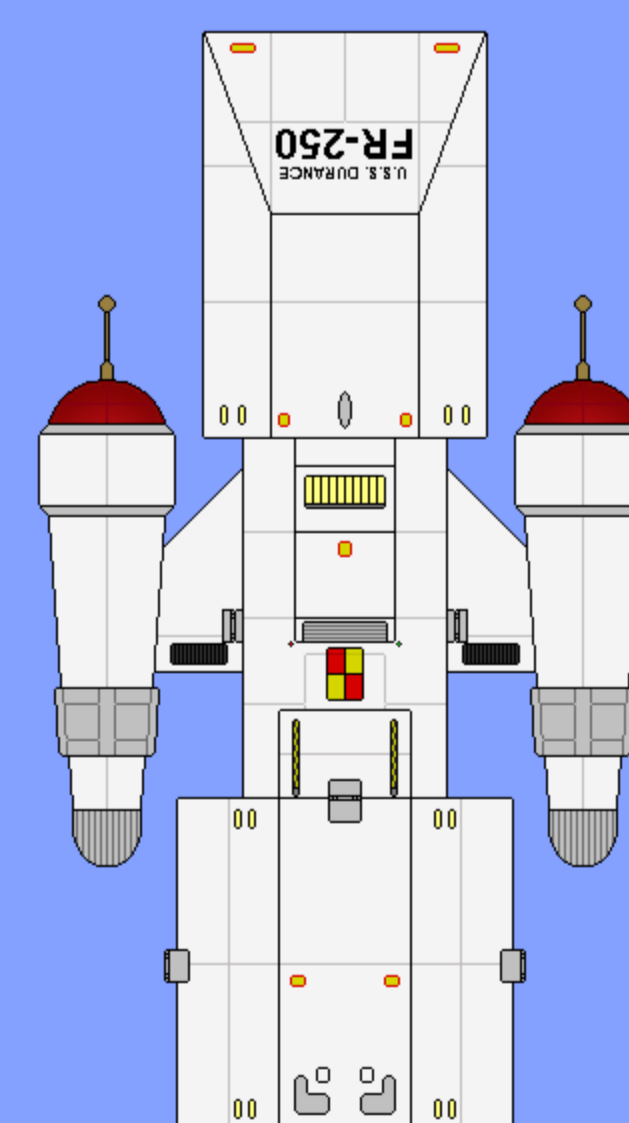



## FORWARD

My contribution to this project would not have been possible without those who came before me. Mainly, CaptShade, whose original drawings laid the foundation for my work by providing me the figurative and literal tools for my own creative output. Nichodo, who was a big help in creating aft and ventral views of various components. RevancheRM, whose ideas and drive helped me get a little more creative and better at something I really enjoy. And, most definitely, Neale "Vance" Davidson, whose enormous volume of work got me interested in doing this in the first place, and for inspiring us all.

- Adrasil

First, as always, thanks to Adrasil. Since partnering with him, I've taken some great artwork and added some context to it. He's really allowed me to scratch my writing itch, to the point it sometimes bleeds, but still feels Oh-So-Good. Next up, of course, is Timo Saloniemi, who's work I've been following for around two decades and I greatly respect. The artwork in these "Starship Recognition Manuals" are 97% based upon the ones he describes textually in his grand opus, the "Hobbyist's Guide to the UFP Starfleet and Its History," and 3% derived from what he has inspired in us.

- RevancheRM

Additional reports may be found at: [starshiptracker.com/deltadynamics](http://starshiptracker.com/deltadynamics)

## CREDITS

ADRASIL: All imagery (unless otherwise credited)  
[www.DeviantArt.com/Adrasil](http://www.DeviantArt.com/Adrasil)

REVANCHEM: All writing (unless otherwise credited)  
[www.DeviantArt.com/RevancheRM](http://www.DeviantArt.com/RevancheRM)

NEALE 'VANCE' DAVIDSON/JAYNZ: Project & cover concepts  
[www.DeviantArt.com/TFVanguard](http://www.DeviantArt.com/TFVanguard)  
[Jaynz.Trekships.org](http://Jaynz.Trekships.org)

STAR TREK DESIGN PROJECT: Source of sponsor icons  
[www.StarTrekDesignProject.com](http://www.StarTrekDesignProject.com)

TIMO SALONIEMI: Author of "Hobbyist's Guide to the UFP Starfleet", the inspiration for these SRMs. A direct link to his Google Drive may be found on most deviations in RevancheRM's gallery.

VIPERAVIATOR: Source of adapted cover starburst  
[www.DeviantArt.com/ViperAviator](http://www.DeviantArt.com/ViperAviator)

### DURANCE CLASS:

- Original inspiration from: Todd Guenther (of Starship Aurora)

- Incorporated parts from: CaptShade

## NOTE FROM THE WRITING EDITOR

These ships do not always exactly match the specifications Timo provides in his technical section for each class, as I've adapted them in ways that allowed them to fit a bit better with the guidance provided by the starship construction rules in Steven Long's "Spacedock". I've also changed some dates around when I found them in conflict with other information Timo has provided. These two books greatly inform my own alpha-canon and I urge you to look up both online, as offered free by their respective authors. (Links to both are provided on the Delta Dynamics site.)

Delta Dynamics' Starship Recognition Manual, along with the Reports and all other similar publications released under that branding, are released as a public service to familiarize interested beings with the historic starship designs and technical developments of the United Federation of Planets Star Fleet, its member and preceding services, and those services of regional galactic neighbors. Despite the occasional presence of a sensitive nature of both those historic events and technical matters discussed herein, the distribution and handling of this publication has been ruled Security Grade 0 (Unclassified) by Star Fleet Support Operations, Office of Security.

Copyright 2419 by Delta Dynamics, Wellington, Earth.

Memory Terra/Memory Alpha Cataloging Data: UFP ITP/TE 7259381460293

Under the laws of the United Federation of Planets and its members, use or reproduction (in whole or in part) of the information contained in this publication—along with proper attribution of its source—is granted. This edition is authorized for distribution only in member star systems of the UFP its territories and possessions, affiliated star systems, and select independent or neutral star systems. "Star Trek" and all related likenesses are copyrights and trademarks of ViacomCBS. This publication has been established for informational and entertainment purposes only. No infringement of copyright nor trademark is intended. There's Klingons on the starboard bow. Jim.



## CONTENTS

DURANCE	TRANSPORT	PG 02:01
ABERDEEN	ESCORT CRUISER	PG 02:07
RIO VERDE	SURVEY VESSEL	PG 02:09
MANHEIM	DESTROYER	PG 02:11
DURANCE (WARTIME FIT)	TRANSPORT	PG 02:13
REDSTONE	TRANSPORT	PG 02:15
CHRYSE	TRANSPORT	PG 02:18
CLASS TIMELINE		PG 03:01
STARSHIP COMPARISON GUIDE		PG 03:05
GLOSSARY		PG 03:06
SPONSORS		PG 03:09
OTHER PUBLICATIONS		PG 03:10



## DURANCE CLASS

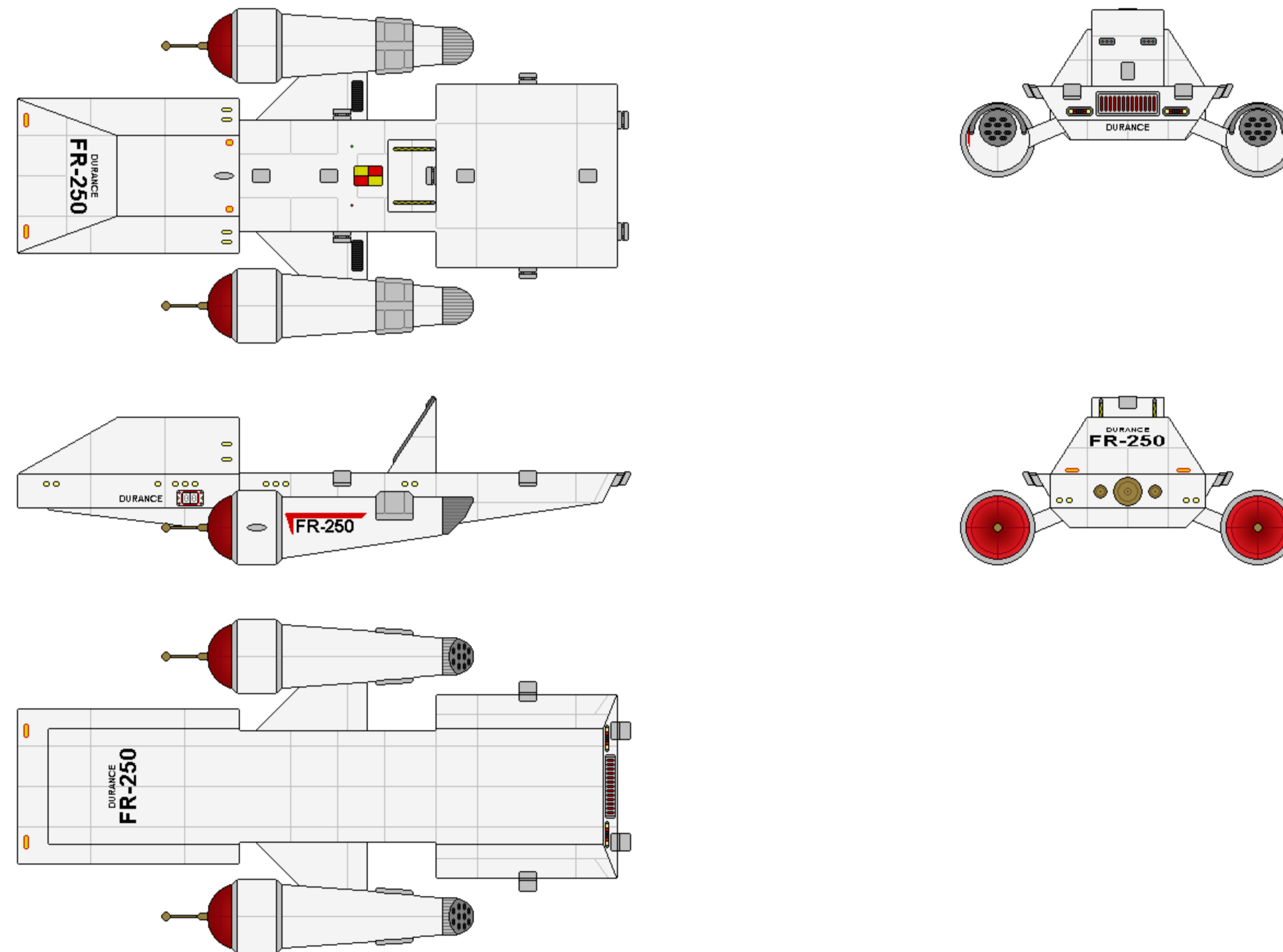

CATEGORY: TRANSPORT  
 OPERATIONAL: 2130 - 2159  
 CONSTRUCTED: 15

DIMENESIONS:  
 LENGTH: 98.7 M  
 BEAM: 57.5 M  
 HEIGHT: 24.7 M  
 MASS: 27.9 M (W/ DSS)  
 42,100 MT

TACTICAL:  
 - 3X 2.0 GW PLASMA CANNONS  
 - 18 TW ELECTROMAGNETIC SHIELD  
 - POLARIZABLE ARMOR PLATING  
 - 2X NAVIGATIONAL DEFLECTORS

PERFORMANCE:  
 CRUISE: WARP 2 (OCU)  
 MAX: WARP 2.2 (OCU)  
 ENDURANCE: 4.5 YEARS

AUXILIARIES:  
 - 1X HEAVY ATMOSPHERIC SHUTTLE  
 OR  
 - 2X CARGO-HANDLING WORK PODS  
 (EITHER OPTIONAL)

COMPLEMENT:  
 OFFICERS: 3  
 ENLISTED: 37  
 PASSENGERS: 10

### AUTHORIZED CONSTRUCTION

THE FOLLOWING SHIPS OF THE ABOVE CLASS WERE AUTHORIZED AS PART OF THE UNITED EARTH STELLAR NAVY BY THE UNITED EARTH DEFENSE PACT (UNDER THE AUTHORITY GRANTED BY THE NEW UNITED NATIONS IN 2069). ALL VESSELS WERE RE-DESIGNATED WITH THE PREFIX "UESS" UPON THE FORMATION OF THE UNITED EARTH STARFLEET IN 2133.

UES DURANCE	FR-250	UES RIO VERDE	FR-258
UES HERON BAY	FR-251	UES CAY'ANDERA	FR-259
UES REMAGEN	FR-252	UES MANHEIM	FR-260
UES AVIOR	FR-253	UES HALSEY	FR-261
UES MANASSA	FR-254	UES SIERRA VISTA	FR-262
UES GRIDLEY	FR-255	UES CHANDELEUR	FR-263
UES CYPRESS	FR-256	UES GREVENMACHER	FR-264
UES ABERDEEN	FR-257		



## DURANCE CLASS

### GENERAL INFORMATION

The Durance class first entered service with the United Earth Stellar Navy in 2130, transitioned to the UE Starfleet in 2133, and fully decommissioned in 2163, the second year of the Federation. Within the overall series, 92 hulls were procured, with 15 specifically of the Durance variation, the others within two later subclasses. These primary Durances were 98.7 meters in length, 57.5 meters on the beam, 27.9 meters high (24.7 meters without the removable DSS), and massed 42,100 metric tons. Three officers led the 37 enlisted crew, for a total of 40. The ships cruised at warp 2 and had a maximum speed of warp 2.2, with a deployment endurance of 4.5 years.

The Durance was armed with three 2-gigawatt plasma cannons, one on the forward dorsal hull, and one on the outboard sides of each nacelle. The ships were protected by an electromagnetic shield, polarizable armor (on the forward hull and sections of the aft), and twin navigational deflectors on the ventral forward hull. They had no laboratories, but could carry one heavy atmospheric shuttle or two cargo handling pods, when outfitted with the optional hanger bay (in lieu of the forward cargo container). Two grappling arms were installed on the forward side of the triangular dorsal support structure (located between the two cargo containers), assisting the work pods in maneuvering the containers or transferring fuel to receiving ships. Within the dorsal support structure were additional fuel tanks.

Prior to the Romulan War (2156–2160), the Durances were the primary means of support for colonies antispinward from Earth, operating between Lorillia and Bolarus. However, as the Rihannsu became more aggressive to the interlopers, UESS Chandeleur (FR-263) was the first of the class to fall. The ships never made too much of an impact on Earth herself, as they had been built in such relatively meager numbers. However, during the war, their perceived potential led to the production of plenty more, in two subclasses: Redstone and Chryse.

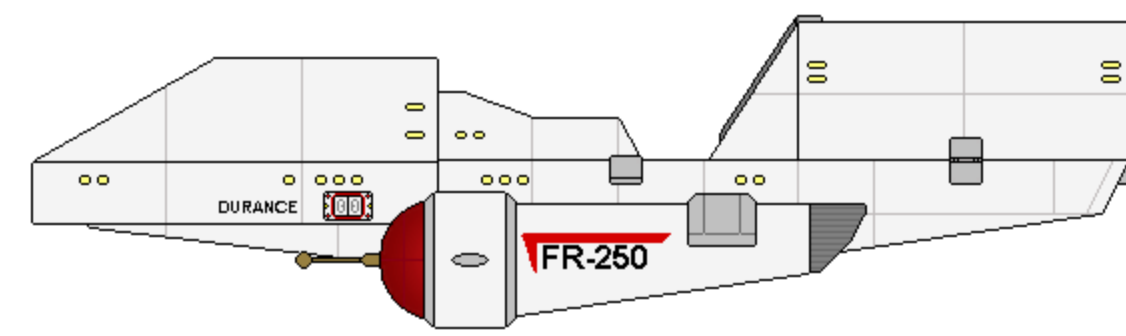

CONFIGURATION 2: 1 CONTAINER & OPTIONAL HANGER POD

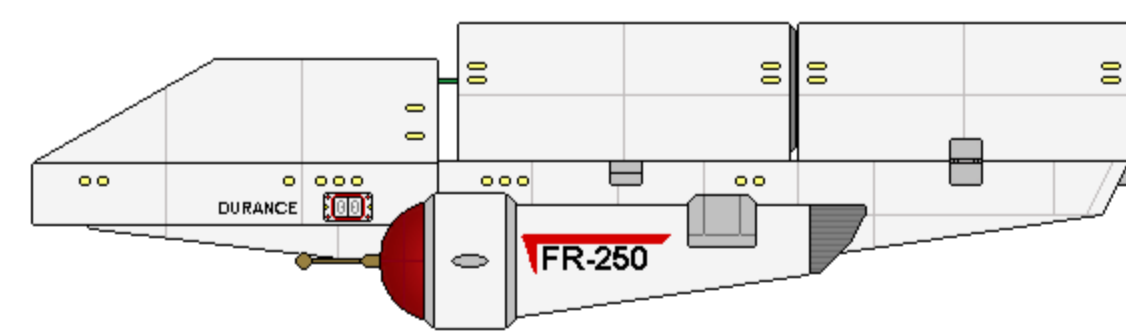

CONFIGURATION 3: 2 CONTAINERS WITH DSS REMOVED

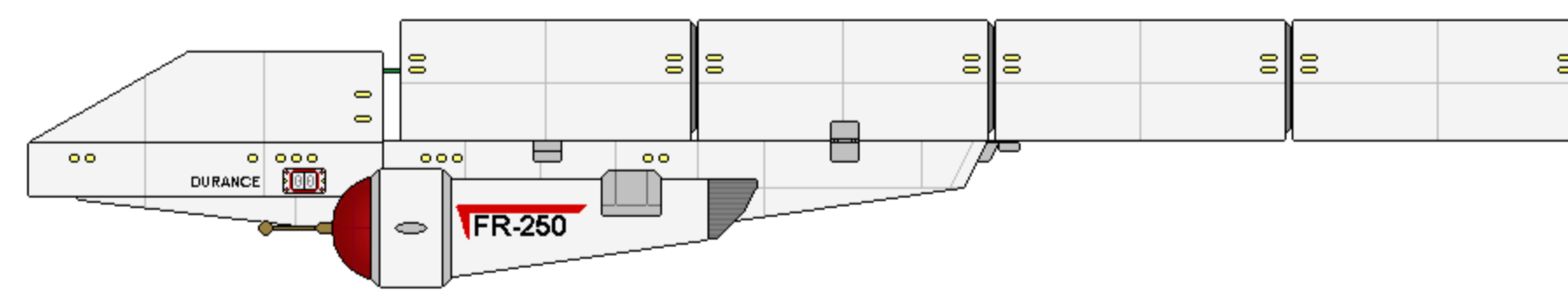

CONFIGURATION 4: 4 CONTAINERS (2 UNDER TOW)

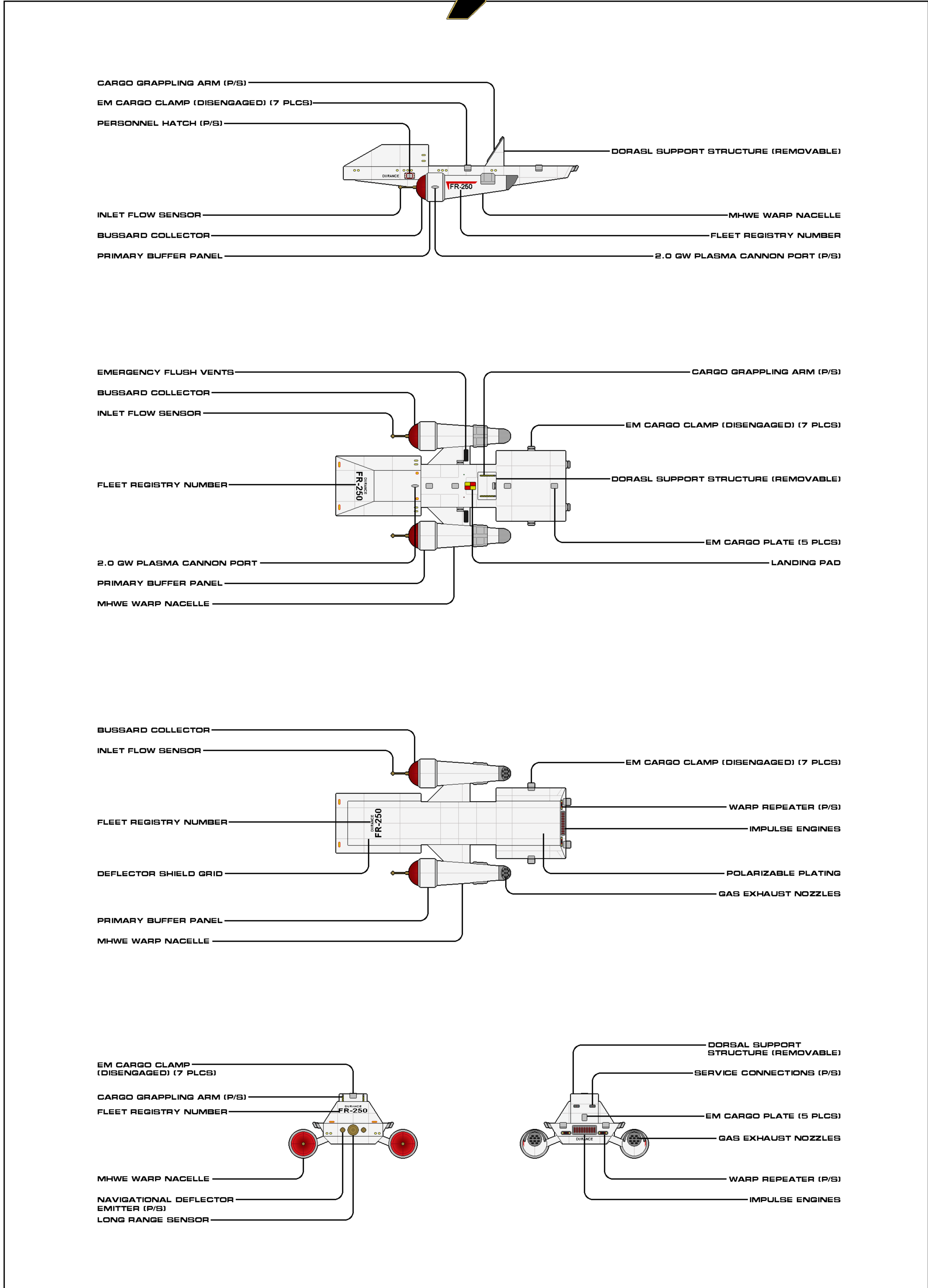

CONFIGURATION 1: UNLADEN WITH DSS ATTACHED



SHEET 1 OF 4

CLASS	DURANCE	CATEGORY	TRANSPORT
VARIANT	PRIMARY	CONSTRUCTED	2130
LENGTH	98.71/104.1 M	BEAM	57.5 M
HEIGHT	24.7/24.9 M	MASS	42,100/42,500 MT
OPERATIONAL	15	RELEASE DATE	2018.0824

Authorized for release by Star Fleet Bureau of Starship Construction

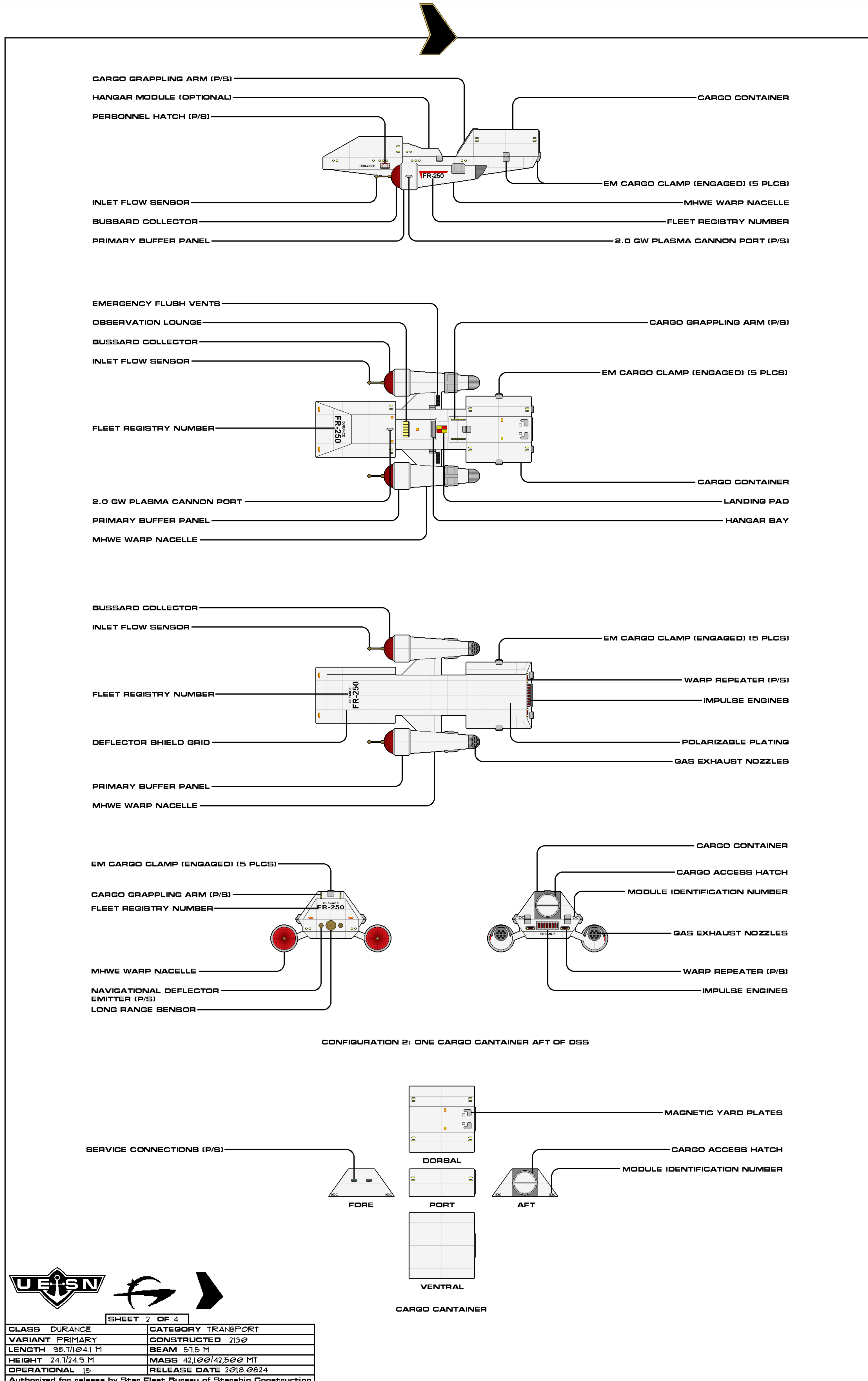

SHEET 2 OF 4

CLASS	DURANCE	CATEGORY	TRANSPORT
VARIANT	PRIMARY	CONSTRUCTED	2130
LENGTH	98.71/104.1 M	BEAM	57.5 M
HEIGHT	24.7/24.9 M	MASS	42,100/42,500 MT
OPERATIONAL	15	RELEASE DATE	2018.0824

Authorized for release by Star Fleet Bureau of Starship Construction

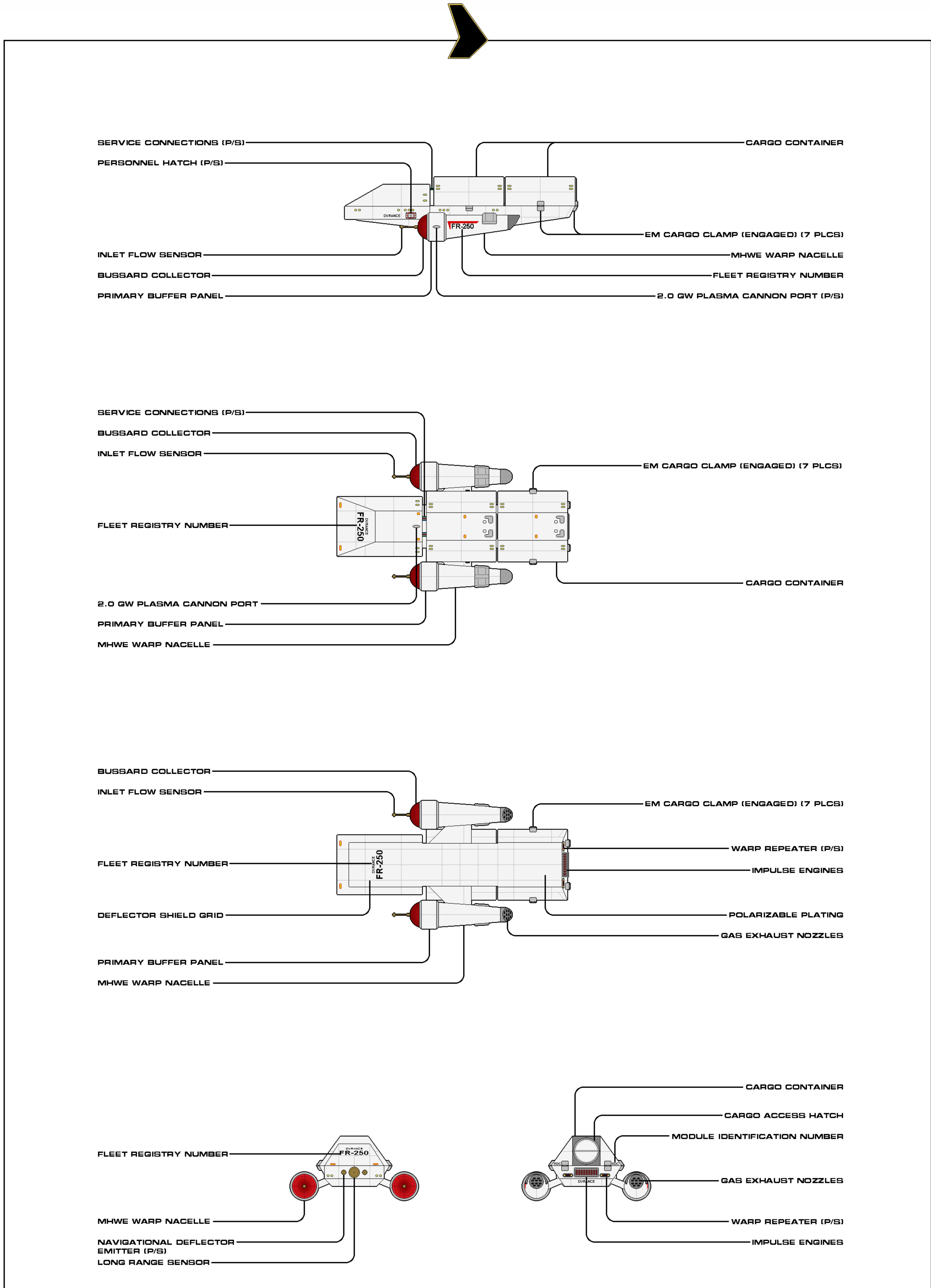

CONFIGURATION 3: FULL CONTAINER LOAD



SHEET 3 OF 4

CLASS	DURANCE	CATEGORY	TRANSPORT
VARIANT	PRIMARY	CONSTRUCTED	2130
LENGTH	98.71041 M	BEAM	51.5 M
HEIGHT	24.7249 M	MASS	42,100/42,500 MT
OPERATIONAL	15	RELEASE DATE	2018.0824

Authorized for release by Star Fleet Bureau of Starship Construction



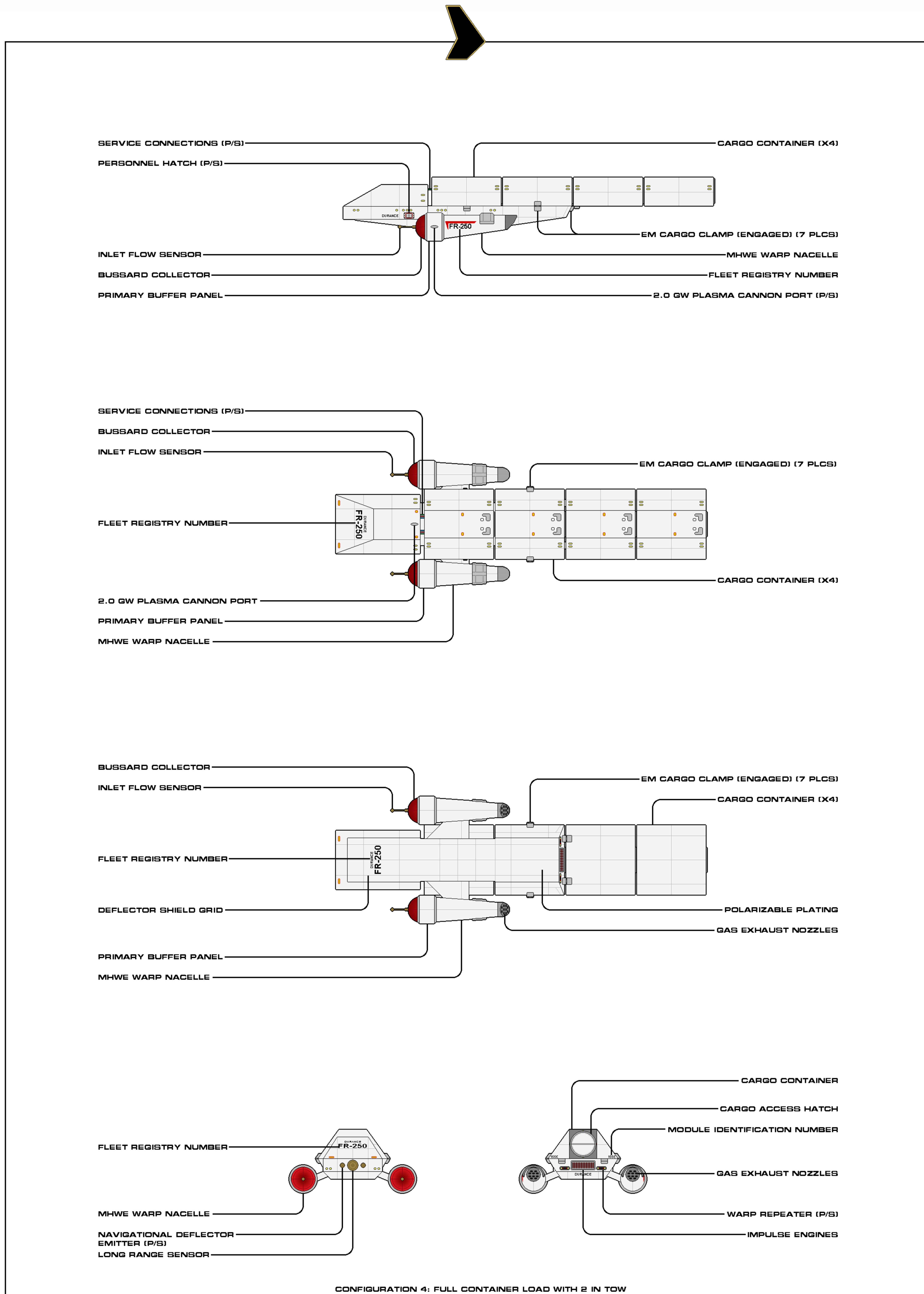

CONFIGURATION 4: FULL CONTAINER LOAD WITH 2 IN TOW



SHEET 4 OF 4

CLASS	DURANCE	CATEGORY	TRANSPORT
VARIANT	PRIMARY	CONSTRUCTED	2130
LENGTH	98.71041 M	BEAM	51.5 M
HEIGHT	24.7249 M	MASS	42,100/42,500 MT
OPERATIONAL	15	RELEASE DATE	2018.0824

Authorized for release by Star Fleet Bureau of Starship Construction



## ABERDEEN SUBCLASS

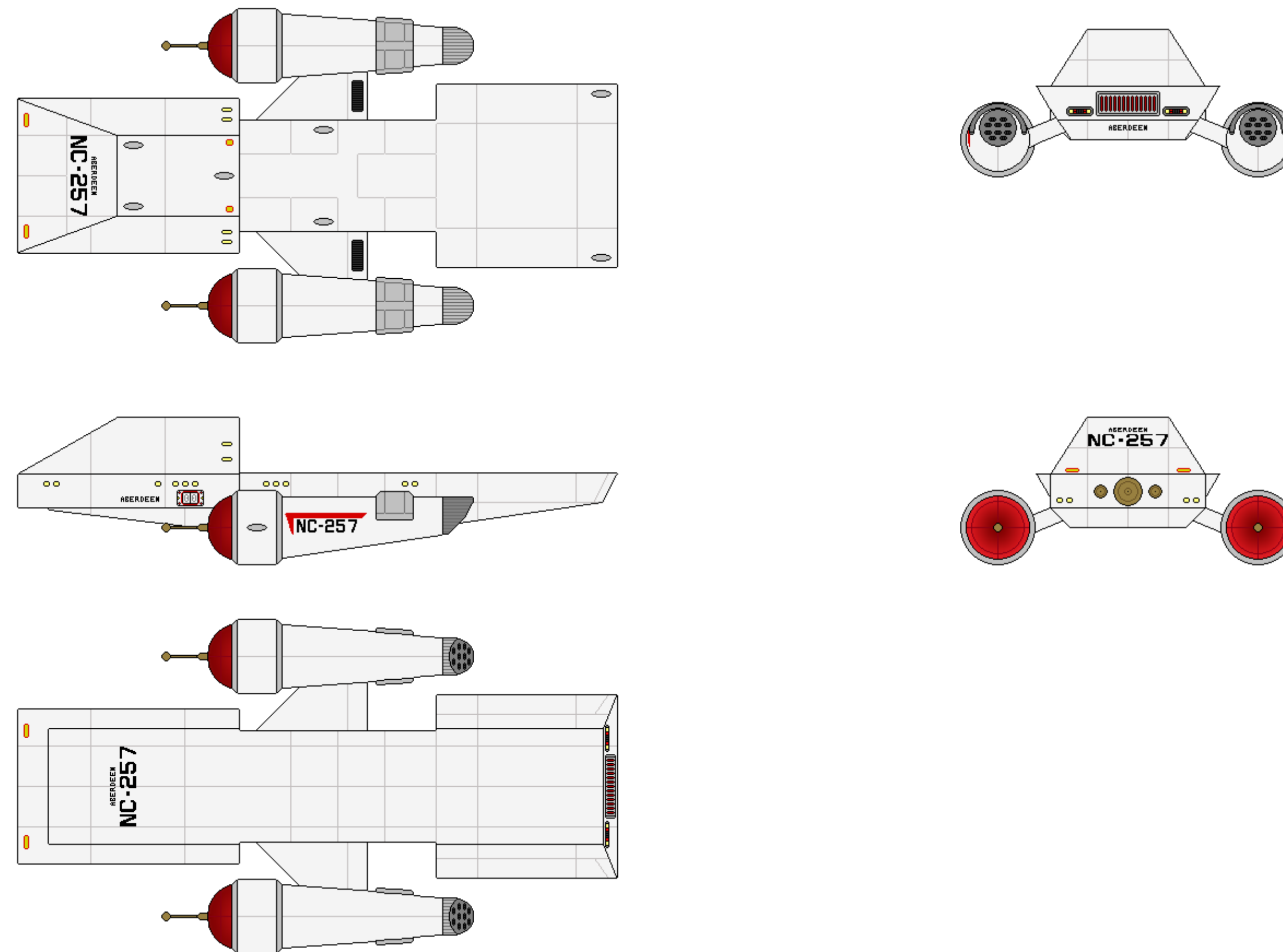

CATEGORY: ESCORT CRUISER  
 OPERATIONAL: 2150S - 2162  
 MODIFIED: 2 (DURANCE)

DIMENESIONS:  
 LENGTH: 97.0 M  
 BEAM: 57.5 M  
 HEIGHT: 24.5 M  
 MASS: 42,100 MT

TACTICAL:  
 - 4X 4.0 GW PLASMA CANNONS  
 - 5X 2.0 GW PLASMA CANNONS  
 - 18 TW ELECTROMAGNETIC SHIELD  
 - POLARIZABLE ARMOR PLATING  
 - 2X NAVIGATIONAL DEFLECTORS

PERFORMANCE:  
 CRUISE: WARP 2 (OCU)  
 MAX: WARP 2.2 (OCU)  
 ENDURANCE: 4.5 YEARS

COMPLEMENT: AUXILIARIES: NONE  
 OFFICERS: 3  
 ENLISTED: 37  
 TROOPS: 10

### AUTHORIZED CONSTRUCTION

THE FOLLOWING SHIPS OF THE ABOVE CLASS WERE AUTHORIZED AS PART OF THE UNITED EARTH STARFLEET BY UNITED EARTH SECURITY COUNCIL APPROPRIATION. ALL VESSELS WERE CONVERTED FROM PREVIOUS DURANCE CONFIGURATION.

UESS ABERDEEN      NC-257      UESS GREVENMACHER      NC-264



## ABERDEEN SUBCLASS

### GENERAL INFORMATION

The Durance class first entered service with the United Earth Stellar Navy in 2130, transitioned to the UE Starfleet in 2133, and fully decommissioned in 2163, the second year of the Federation. Within the overall series, 92 hulls were procured, with 2 modified to the Aberdeen variation, in the years prior to the Romulan War (2156-2160). These two had the same dimensions as the primary Durances, but were modified as prototype "escort cruisers" to protect commerce in the area when it became obvious that the expected lifetime of unescorted vessels near Triangulum Australe was lower than the reaction time of nearby UESF forces. Featuring added plasma weapons and omitting both the cargo pods and the dorsal support structure, the ships had no true offensive capabilities. They proved to be insufficient in protecting convoys against vicious Rihannsu attacks after the beginning of open war.

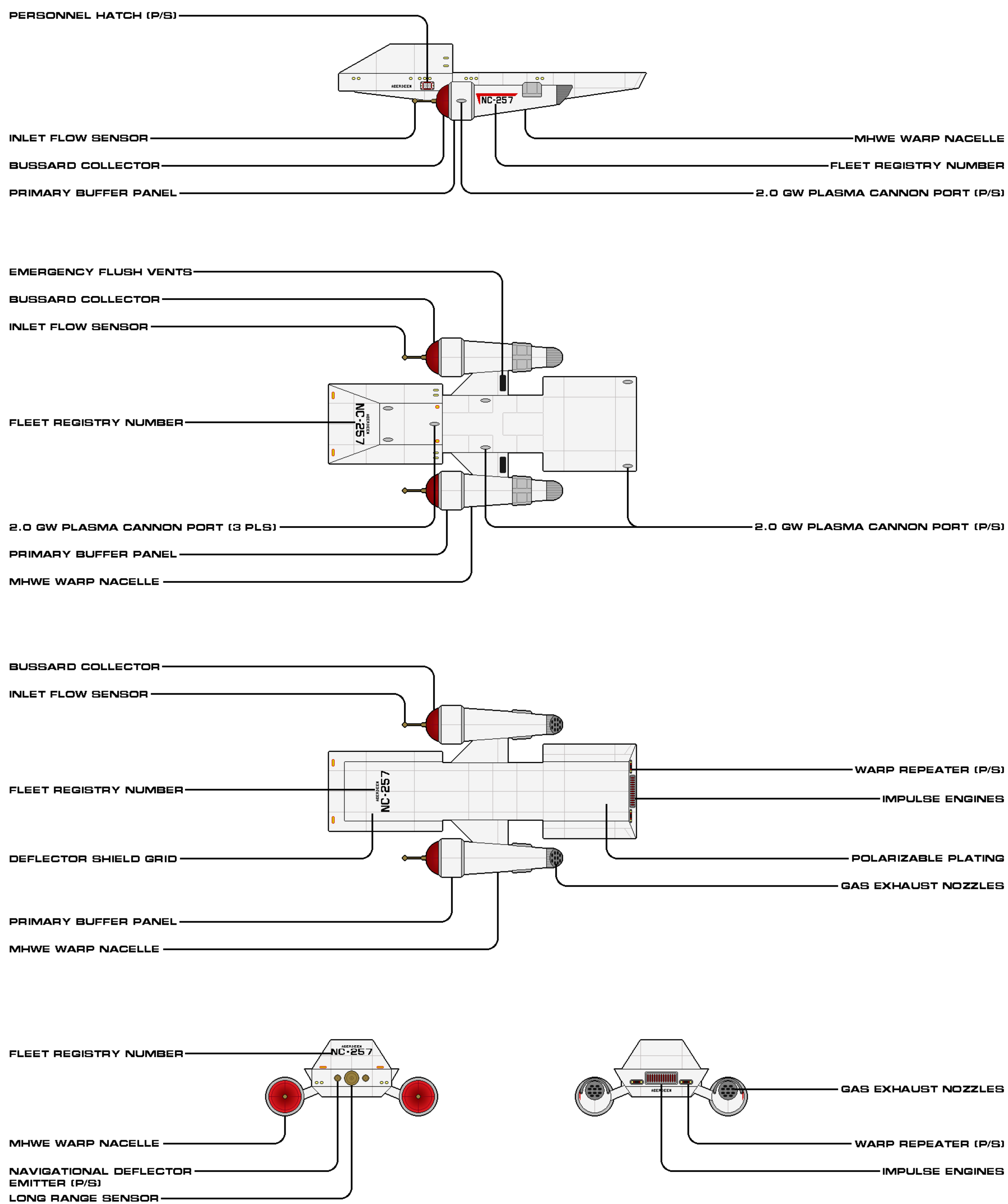

SHEET 1 OF 1

CLASS	DURANCE	CATEGORY	ESCORT CRUISER
VARIANT	ABERDEEN	CONSTRUCTED	21509
LENGTH	51.0 M	BEAM	51.5 M
HEIGHT	24.5 M	MASS	42,100 MT
OPERATIONAL	2	RELEASE DATE	2018.0824

Authorized for release by Star Fleet Bureau of Starship Construction



RIO VERDE SUBCLASS

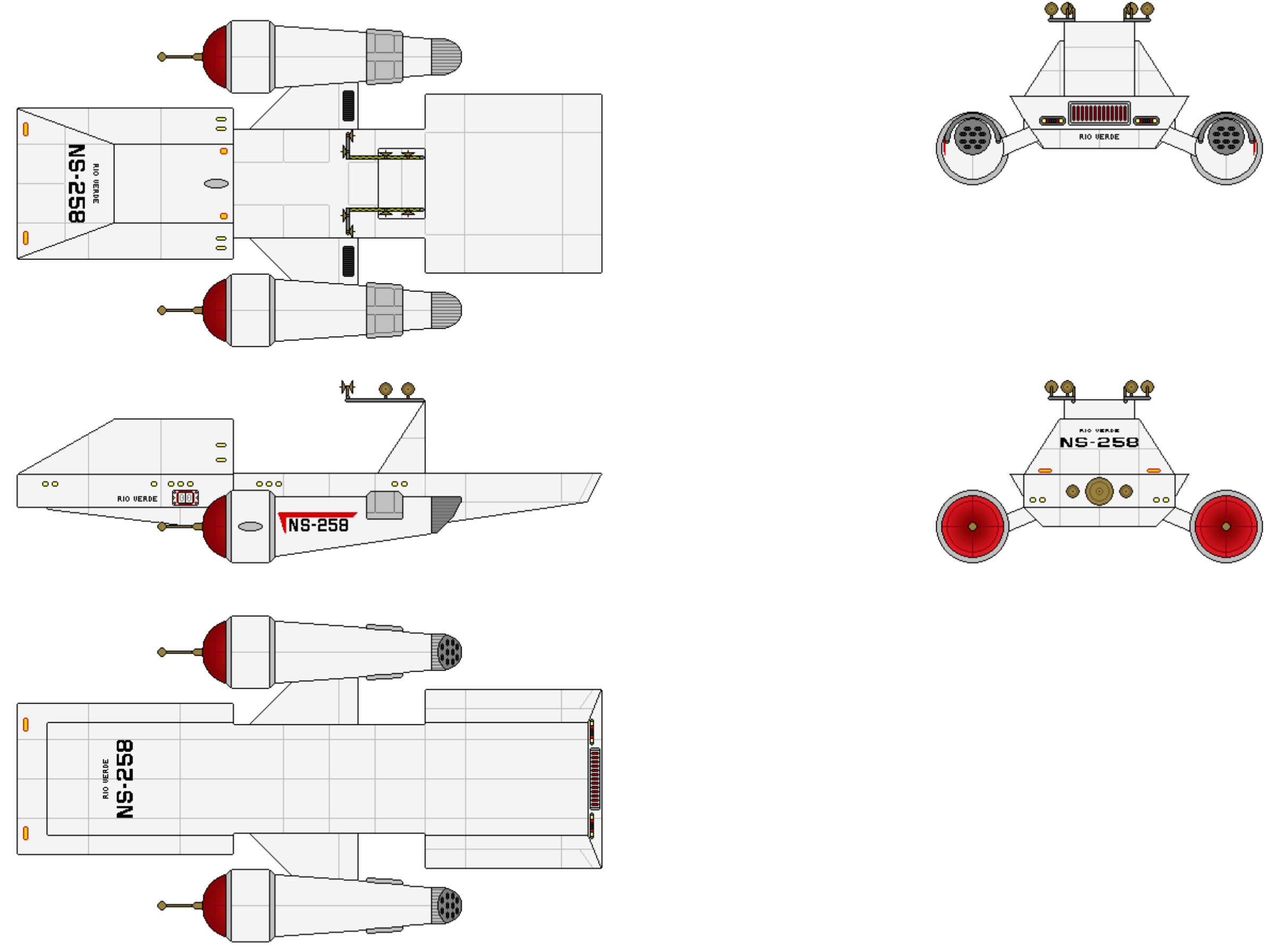

CATEGORY: SURVEY VESSEL  
 OPERATIONAL: 2150S - 2163  
 MODIFIED: 1 (DURANCE)

DIMENESIONS:  
 LENGTH: 97.0 M  
 BEAM: 57.5 M  
 HEIGHT: 27.9 M  
 MASS: 42,100 MT

TACTICAL:  
 - 3X 2.0 GW PLASMA CANNONS  
 - 18 TW ELECTROMAGNETIC SHIELD  
 - POLARIZABLE ARMOR PLATING  
 - 2X NAVIGATIONAL DEFLECTORS

PERFORMANCE:  
 CRUISE: WARP 2 (OCU)  
 MAX: WARP 2.2 (OCU)  
 ENDURANCE: 4.5 YEARS

COMPLEMENT: AUXILIARIES: NONE  
 OFFICERS: 3  
 ENLISTED: 37  
 PASSENGERS: 10

AUTHORIZED CONSTRUCTION

THE FOLLOWING SHIPS OF THE ABOVE CLASS WERE AUTHORIZED AS PART OF THE UNITED EARTH STARFLEET BY UNITED EARTH SECURITY COUNCIL APPROPRIATION. ALL VESSELS WERE CONVERTED FROM PREVIOUS DURANCE CONFIGURATION.

UESS RIO VERDE      NS-258



## RIO VERDE SUBCLASS

### GENERAL INFORMATION

The UESS Rio Verde was the only Durance to be converted from her original transport mission to a scientific survey one, with the removal of all services support for the cargo containers and installing commercial off-the-shelf sensors onto the articulated, extendable cargo-handling grapppler arms. The ship could now enter fields of specific interest, such as asteroid belts or nebulae, and examine multiple scientific curiosities at the same time, or even focus on one particular target from slightly different vectors. If ship's orientation allowed, the forward sensors could also be engaged, siphoning near-iso amounts of data relatively quickly. The ten Durance passenger billets were well-suited to host visiting scientists.

The concept of a dedicated and versatile survey vessel rang true within certain branches of the nascent UFP Star Fleet and led to vessel classes that were much better equipped and manned for the role.

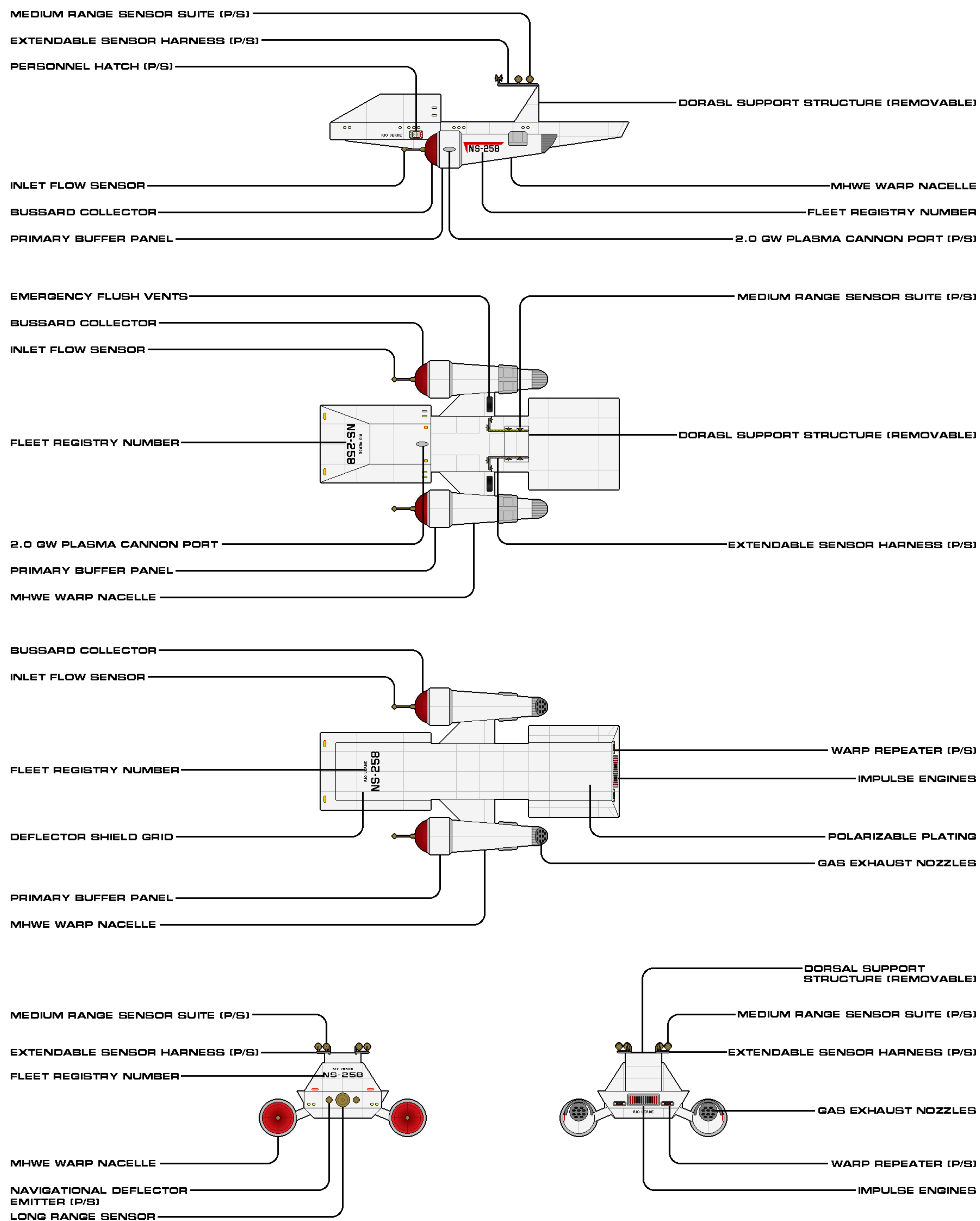

CLASS	DURANCE	CATEGORY	SURVEY VESSEL
VARIANT	RIO VERDE	CONSTRUCTED	21509
LENGTH	57.0 M	BEAM	57.5 M
HEIGHT	27.9 M	MASS	42,100 MT
OPERATIONAL	1	RELEASE DATE	2018.0824

Authorized for release by Star Fleet Bureau of Starship Construction



**MANHEIM SUBCLASS**

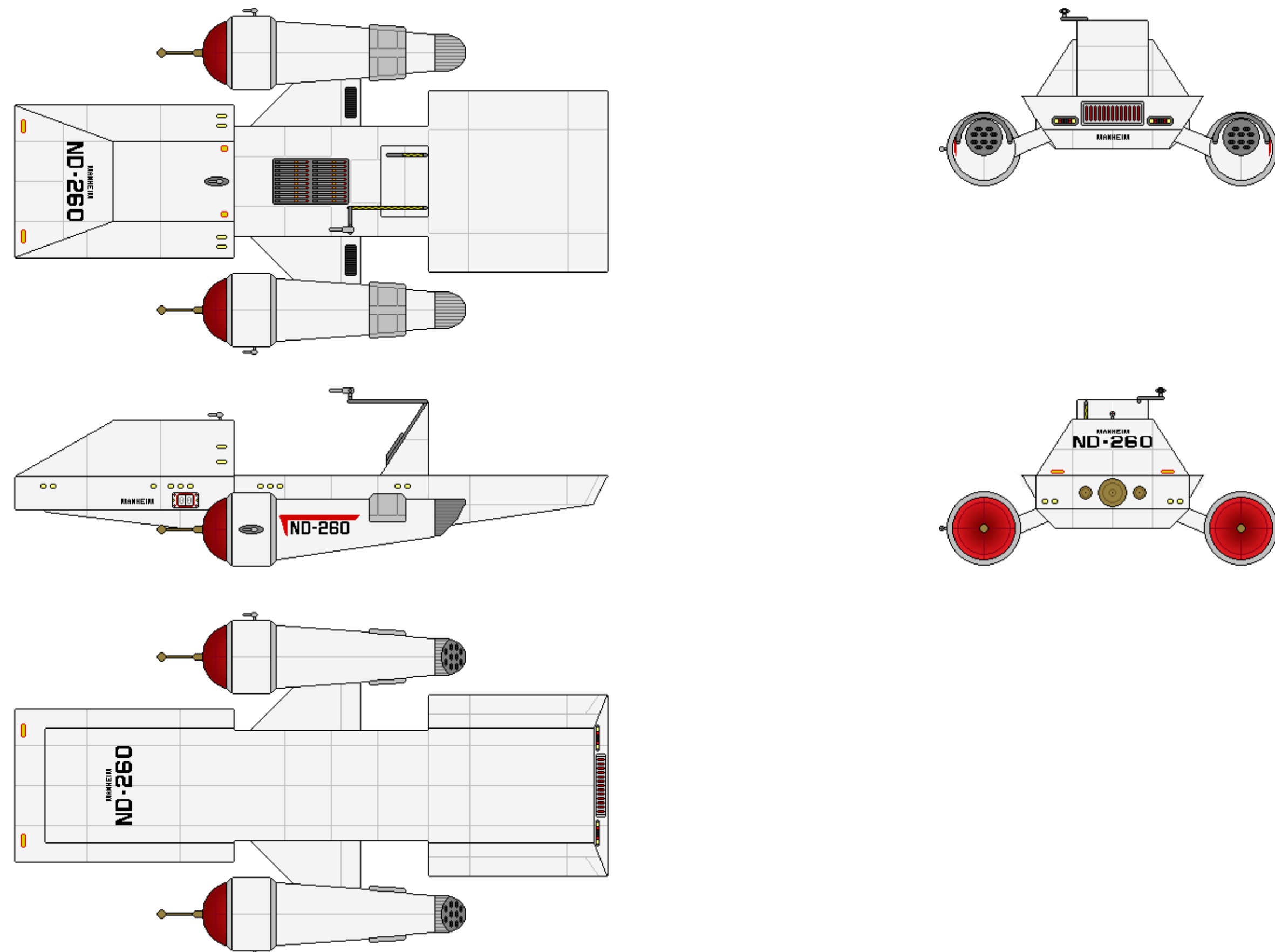

CATEGORY: DESTROYER  
 OPERATIONAL: 2150S - 2163  
 MODIFIED: 2 (DURANCE)

DIMENESIONS:  
 LENGTH: 97.0 M  
 BEAM: 57.5 M  
 HEIGHT: 24.5 M  
 MASS: 42,100 MT

TACTICAL:  
 - 3X 2.0 GW PLASMA CANNONS  
 - 1x 500 GW PHASE CANNON  
 - 1x MISSILE LAUNCH SYSTEM  
 (W/ 20 MISSILES)  
 - 18 TW ELECTROMAGNETIC SHIELD  
 - POLARIZABLE ARMOR PLATING  
 - 2X NAVIGATIONAL DEFLECTORS

PERFORMANCE:  
 CRUISE: WARP 2 (OCU)  
 MAX: WARP 2.2 (OCU)  
 ENDURANCE: 4.5 YEARS

COMPLEMENT:  
 OFFICERS: 3  
 ENLISTED: 37  
 TROOPS: 10

AUXILIARIES: NONE

**AUTHORIZED CONSTRUCTION**

THE FOLLOWING SHIPS OF THE ABOVE CLASS WERE AUTHORIZED AS PART OF THE UNITED EARTH STARFLEET BY UNITED EARTH SECURITY COUNCIL APPROPRIATION. ALL VESSELS WERE CONVERTED FROM PREVIOUS DURANCE CONFIGURATION.

UESS HERON BAY      ND-251      UESS MANHEIM      ND-260



## MANHEIM SUBCLASS

### GENERAL INFORMATION

The Manheim subclass of the Durances was created as a test of the configurability and utility of the primary class, with a specific focus on the march to war spinward of Earth in the early 2150s. To convert the UESS Manheim (FR-260) into a destroyer, spaces immediately below the amidships cargo platform were cleared to create a missile storage bay, with a retractable dorsal hatch. The versatile cargo grappling arms, now unemployed with the removal of the transport mission, were reconfigured to host a 500 GW phased particle cannon (port) and a fusion missile launcher (starboard). Both arms allowed for greater articulation than the installed plasma cannon turrets provided; the launcher would extend into the missile bay and select the designated ordnance, before then swiveling to the target's vector. Follow-on launches could take place, on differing vectors, within 24 seconds of each other.

UESS Heron Bay (FR-251) was the only other Durance to follow UESS Manheim out of the refit slips as a destroyer and both retained their combatant roles throughout the conflict and following it. However, the necessity of dedicated combatant lineages was evident, due to numerous logistics, training, and capacity reasons highlighted by the numerous roles the Durances filled.

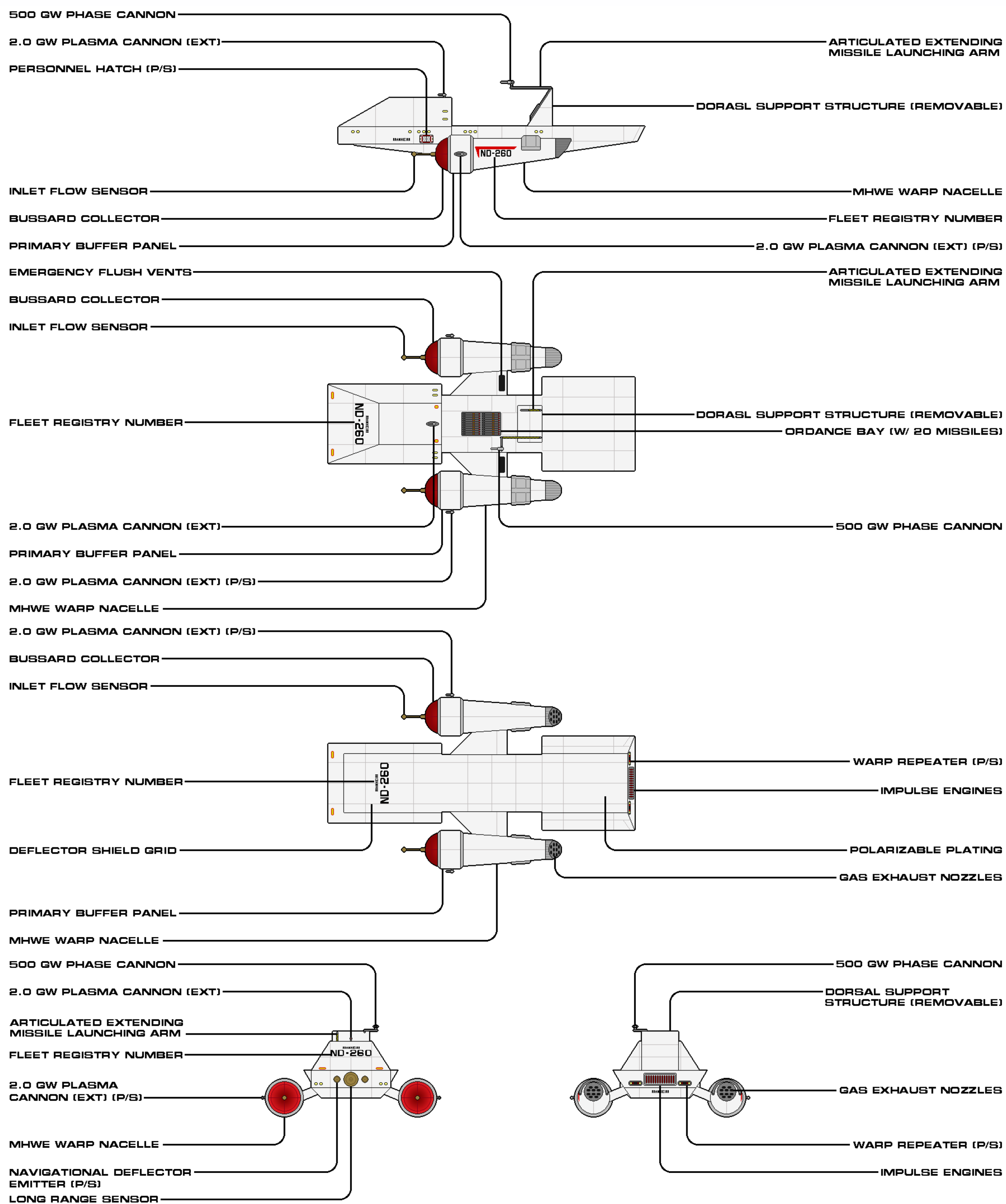

SHEET 1 OF 1

CLASS DURANCE	CATEGORY DESTROYER
VARIANT MANHEIM	CONSTRUCTED 21509
LENGTH 51.0 M	BEAM 51.5 M
HEIGHT 24.5 M	MASS 42,100 MT
OPERATIONAL 2	RELEASE DATE 2018.0824

Authorized for release by Star Fleet Bureau of Starship Construction



**DURANCE CLASS (WARTIME FIT)**

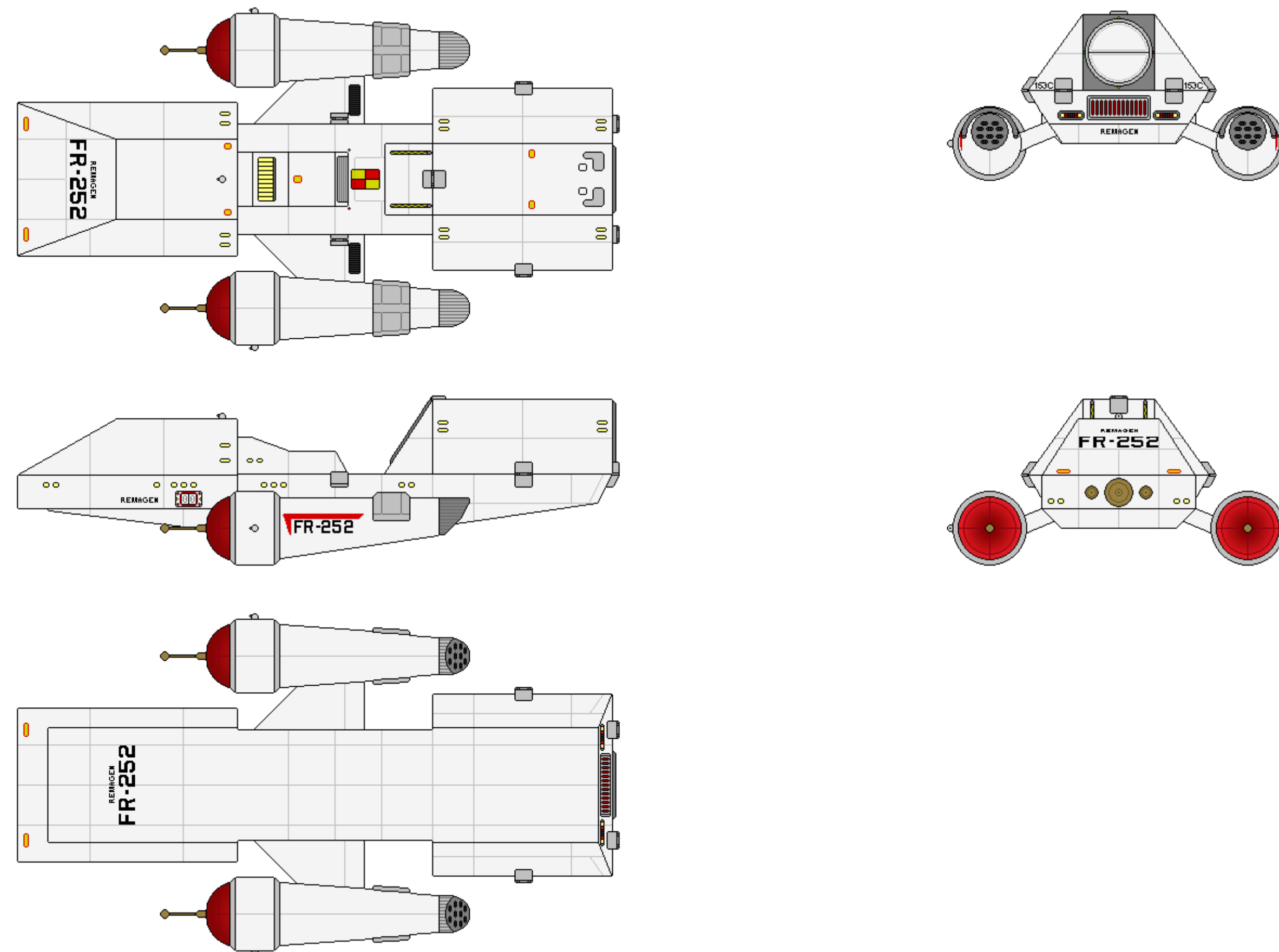

**CATEGORY:** TRANSPORT  
**OPERATIONAL:** 2157 - 2163  
**MODIFIED:** 9

**DIMENESIONS:**  
 LENGTH: 98.7 M  
 BEAM: 59.4 M  
 HEIGHT: 24.7 M  
 MASS: 27.9 M (W/ DSS)  
 42,100 MT

**PERFORMANCE:**  
 CRUISE: WARP 2 (OCU)  
 MAX: WARP 2.2 (OCU)  
 ENDURANCE: 4.5 YEARS

**COMPLEMENT:**  
 OFFICERS: 3  
 ENLISTED: 37  
 PASSENGERS: 10

**TACTICAL:**  
 - 3x 300 MW LASER TURRETS  
 - 18 TW ELECTROMAGNETIC SHIELD  
 - POLARIZABLE ARMOR PLATING  
 - 2X NAVIGATIONAL DEFLECTORS

**AUXILIARIES:**  
 - 1X HEAVY ATMOSPHERIC SHUTTLE  
 OR  
 - 2X CARGO-HANDLING WORK PODS  
 (EITHER OPTIONAL)

**AUTHORIZED CONSTRUCTION**

THE FOLLOWING SHIPS OF THE ABOVE CLASS WERE AUTHORIZED AS PART OF THE UNITED EARTH STARFLEET BY UNITED EARTH SECURITY COUNCIL APPROPRIATION. ALL VESSELS WERE CONVERTED FROM PREVIOUS DURANCE CONFIGURATION.

UESS DURANCE	FR-250	UESS CYPRESS	FR-256
UESS REMAGEN	FR-252	UESS CAY'ANDERA	FR-259
UESS AVIOR	FR-253	UESS HALSEY	FR-261
UESS MANASSA	FR-254	UESS SIERRA VISTA	FR-262
UESS GRIDLEY	FR-255		





## DURANCE CLASS (WARTIME FIT)

### GENERAL INFORMATION

During the Romulan War, as individual Durance class ships entered range of dockyards equipped to upgrade them, their plasma cannons were replaced with 300 MW laser turrets, with a range of 230 nautical miles. The ships were protected by an electromagnetic shield, polarizable armor (on the forward hull and sections of the aft), and twin navigational deflectors on the ventral forward hull. The Durances had no laboratories, but could carry one heavy atmospheric shuttle or two cargo handling pods, when the optional hanger bay was equipped (in lieu of the forward cargo container). Two grappling arms were installed on the forward side of the triangular dorsal support structure (located between the two cargo containers). They could assist the work pods in maneuvering the containers or transferring fuel to receiving ships. Within the dorsal support structure were additional fuel tanks.

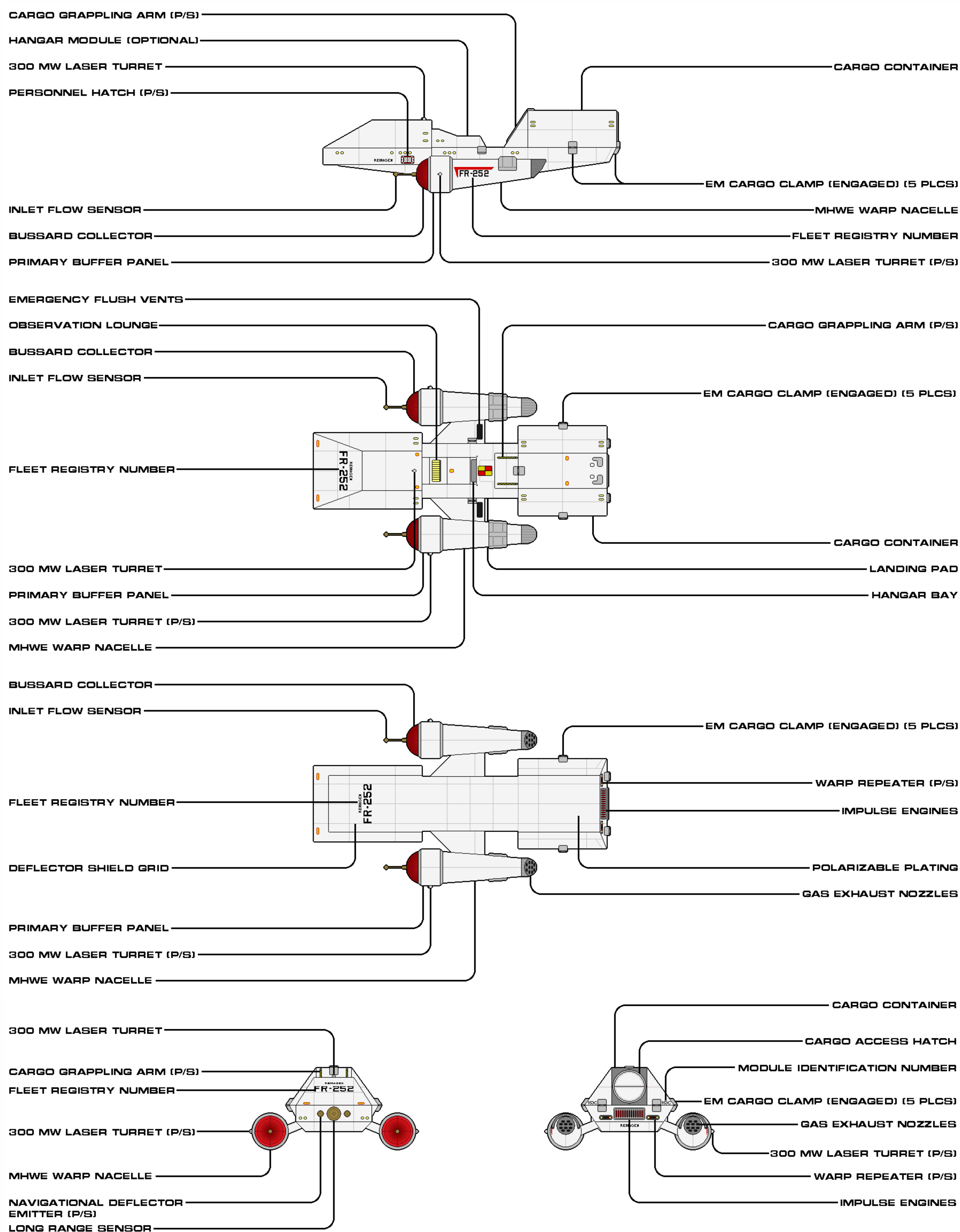

SHEET 1 OF 1

CLASS	DURANCE	CATEGORY	TRANSPORT
VARIANT	PRIMARY WARTIME FIT	CONSTRUCTED	2151
LENGTH	98.1 M	BEAM	59.4 M
HEIGHT	24.1 M	MASS	42,200 MT
OPERATIONAL	9	RELEASE DATE	2018.0824

Authorized for release by Star Fleet Bureau of Starship Construction



## REDSTONE SUBCLASS

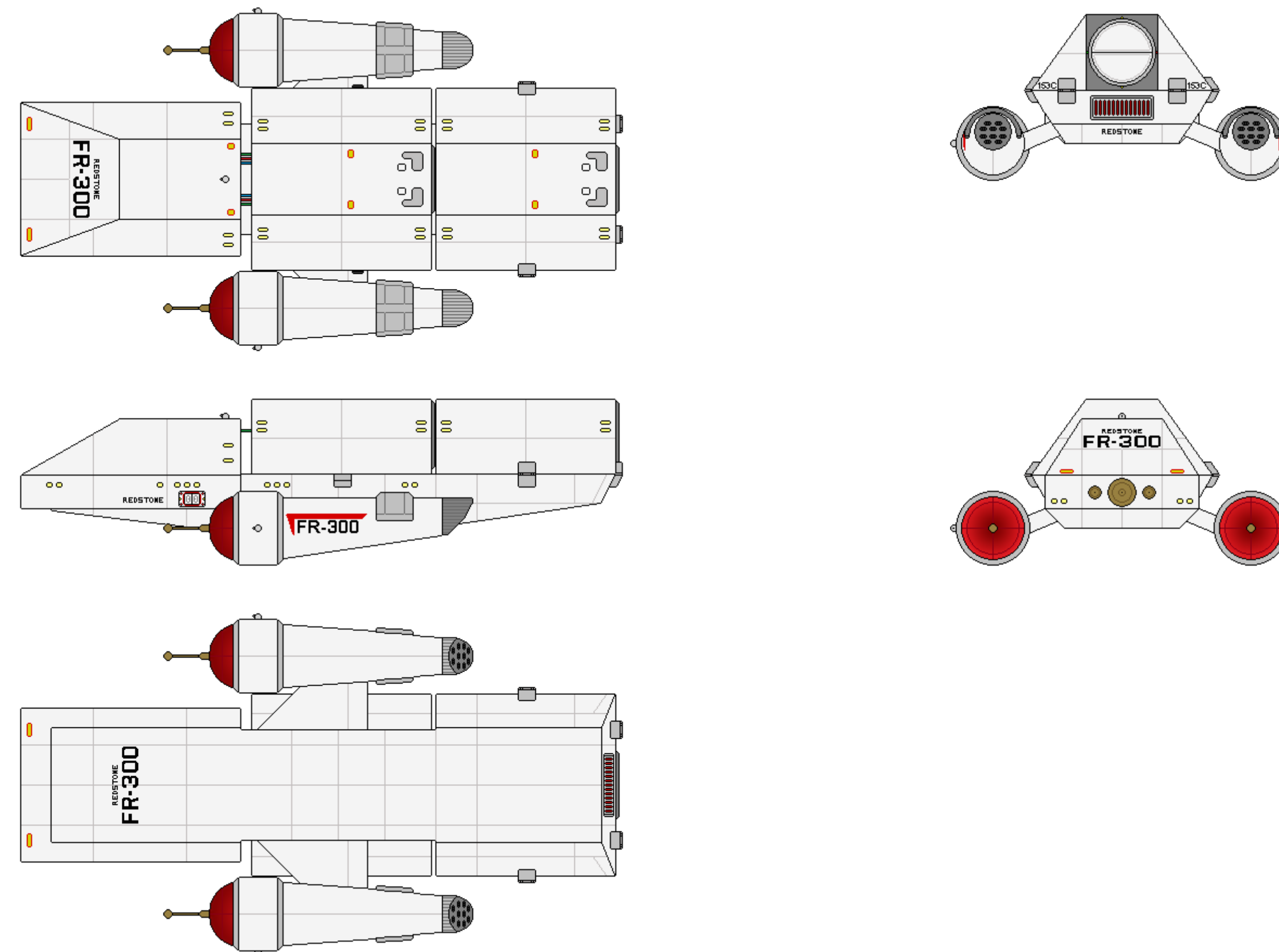

CATEGORY: TRANSPORT  
 OPERATIONAL: 2156 - 2163  
 CONSTRUCTED: 38

DIMENESIONS:  
 LENGTH: 97.0 M  
 BEAM: 59.4 M  
 HEIGHT: 25.4 M  
 MASS: 42,650 MT

TACTICAL:  
 - 3x 300 MW LASER TURRETS  
 - 18 TW ELECTROMAGNETIC SHIELD  
 - POLARIZABLE ARMOR PLATING  
 - 2X NAVIGATIONAL DEFLECTORS

PERFORMANCE:  
 CRUISE: WARP 2 (OCU)  
 MAX: WARP 2.2 (OCU)  
 ENDURANCE: 4.5 YEARS

AUXILIARIES:  
 - 2X CARGO-HANDLING WORK PODS

COMPLEMENT:  
 OFFICERS: 3  
 ENLISTED: 34  
 PASSENGERS: 10

### AUTHORIZED CONSTRUCTION

THE FOLLOWING SHIPS OF THE ABOVE CLASS WERE AUTHORIZED AS PART OF THE UNITED EARTH STARFLEET BY UNITED EARTH SECURITY COUNCIL APPROPRIATION. ALL VESSELS WERE CONVERTED FROM PREVIOUS DURANCE CONFIGURATION.

UESS REDSTONE	FR-300	UESS LOBBER	FR-310
UESS MATADOR	FR-301	UESS LACROSSE	FR-311
UESS REGULUS	FR-302	UESS TITAN	FR-312
UESS BULLPUP	FR-303	UESS CORPORAL	FR-313
UESS BOMARC	FR-304	UESS SHILLELAGH	FR-314
UESS ATLAS	FR-305	UESS PING-PONG	FR-315
UESS HERCULES	FR-306	UESS THOR	FR-316
UESS BUMPER	FR-307	UESS SPARROW	FR-317
UESS HONEYCOMB	FR-308	UESS HONEST JOHN	FR-318
UESS POLARIS	FR-309	UESS LITTLE JOHN	FR-319



## REDSTONE SUBCLASS

### AUTHORIZED CONSTRUCTION (CONTINUED)

UESS TARTAR	FR-320	UESS SIDEWINDER	FR-329
UESS SERGEANT	FR-321	UESS HERMES	FR-330
UESS QUAIL	FR-322	UESS TALOS	FR-331
UESS VIPER	FR-323	UESS DART	FR-332
UESS FALCON	FR-324	UESS LARK	FR-333
UESS MACE	FR-325	UESS FIREBEE	FR-334
UESS HAWK	FR-326	UESS FLASH	FR-335
UESS PLATO	FR-327	UESS TERRIER	FR-336
UESS NIKE	FR-328	UESS AJAX	FR-337

---

### GENERAL INFORMATION

The Redstone subclass of the Durance series first entered service with the United Earth Starfleet during the Romulan War (2156–2160), and the last was decommissioned in 2163, in the second year of the Federation. Thirty-eight Redstones were procured, on a cost-cutting measure to acquire more logistical support for the rapidly maneuvering front-line forces. The savings were acquired by not installing the expensive and massive warp repeaters. This prevented, of course, the towing of any cargo, including the class-custom Durance-style cargo containers; if it did not fit within the warp field-encased cargo deck, it did not go. This reduced the types and amounts of cargo to be delivered, but the quicker construction meant more ships in the lanes, so the trade-off was seen as equitable. However, one unanticipated aspect of the "shorter" transports was that the UESF was less willing to spare them for longer endurance missions, which meant the original Durances often undertook the longer deployments.

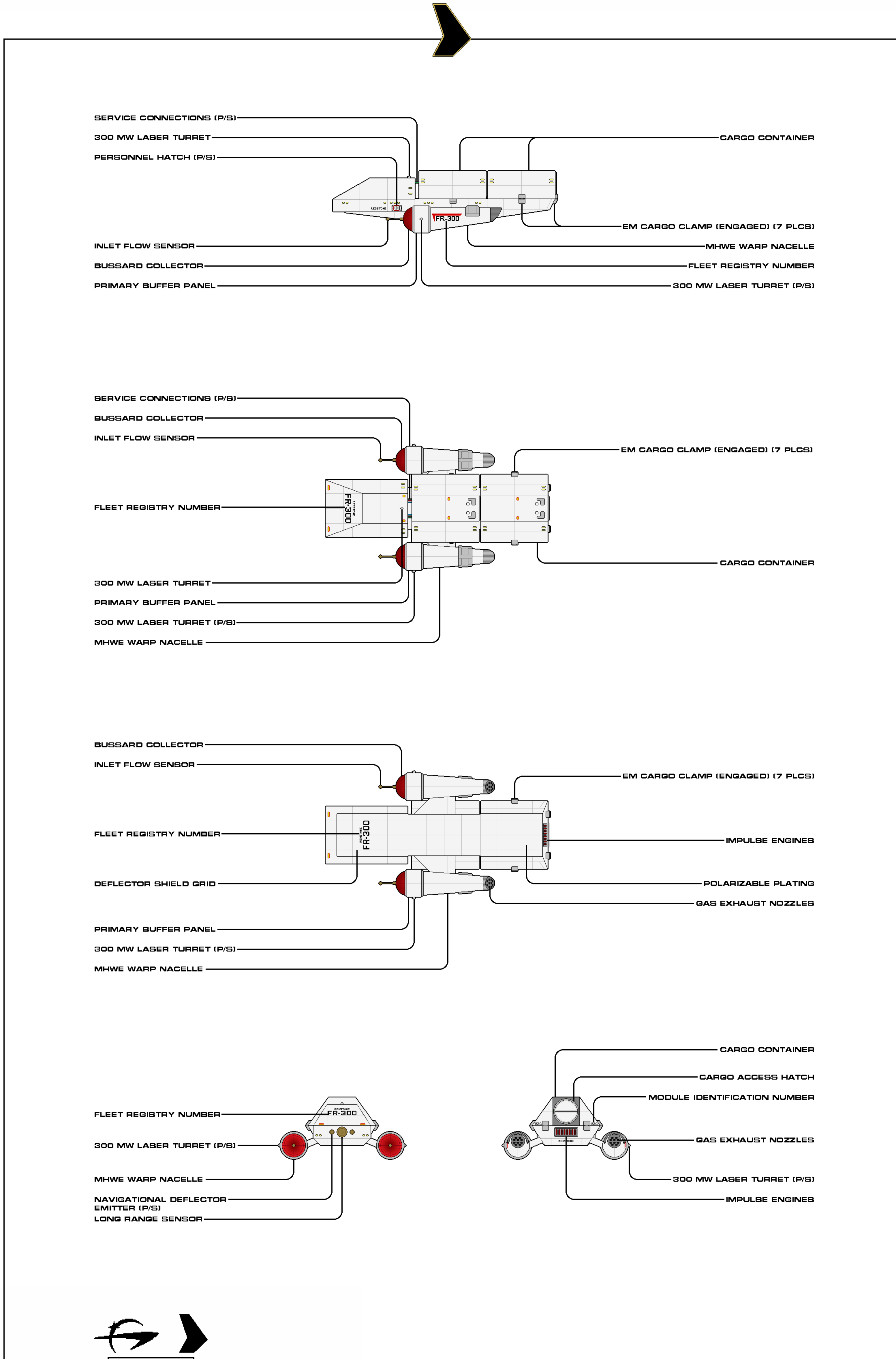

SHEET 1 OF 1

CLASS DURANCE	CATEGORY TRANSPORT
VARIANT REDSTONE	CONSTRUCTED 2156
LENGTH 97.0 M	BEAM 59.4 M
HEIGHT 25.4 M	MASS 42,650 MT
OPERATIONAL 38	RELEASE DATE 2018.0824

Authorized for release by Star Fleet Bureau of Starship Construction



## CHRYSE SUBCLASS

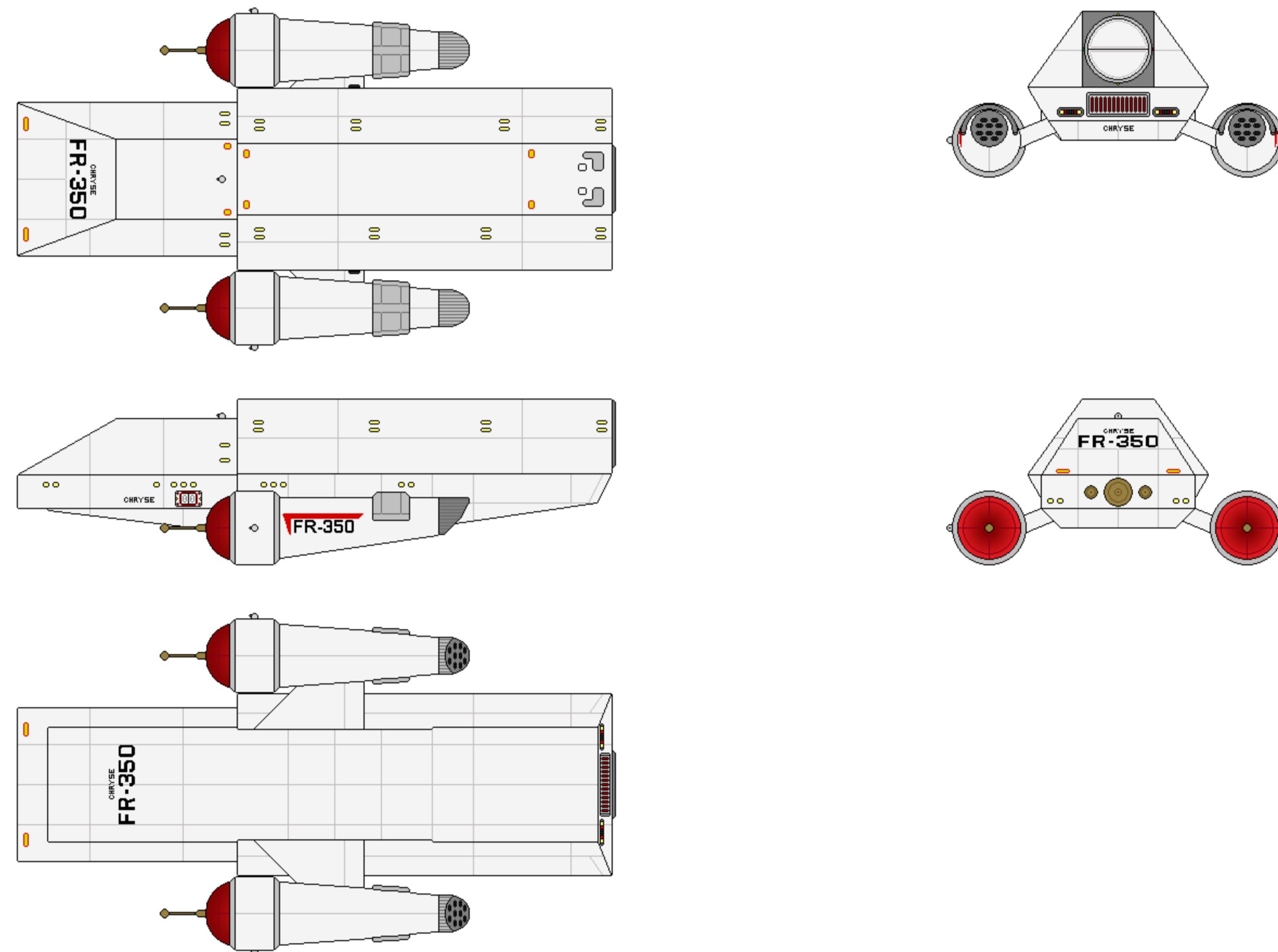

CATEGORY: TRANSPORT  
 OPERATIONAL: 2158 - 2163  
 CONSTRUCTED: 39

DIMENESIONS:  
 LENGTH: 97.5 M  
 BEAM: 59.4 M  
 HEIGHT: 27.7 M  
 MASS: 42,400 MT

TACTICAL:  
 - 3x 300 MW LASER TURRETS  
 - 18 TW ELECTROMAGNETIC SHIELD  
 - POLARIZABLE ARMOR PLATING  
 - 2X NAVIGATIONAL DEFLECTORS

PERFORMANCE:  
 CRUISE: WARP 2 (OCU)  
 MAX: WARP 2.2 (OCU)  
 ENDURANCE: 4.5 YEARS

AUXILIARIES:  
 - 2X CARGO-HANDLING WORK PODS

COMPLEMENT:  
 OFFICERS: 3  
 ENLISTED: 41  
 PASSENGERS: 10

### AUTHORIZED CONSTRUCTION

THE FOLLOWING SHIPS OF THE ABOVE CLASS WERE AUTHORIZED AS PART OF THE UNITED EARTH STARFLEET BY UNITED EARTH SECURITY COUNCIL APPROPRIATION. ALL VESSELS WERE CONVERTED FROM PREVIOUS DURANCE CONFIGURATION.

UESS CHRYSE	FR-350	UESS ZETES	FR-360
UESS ERIOPIS	FR-351	UESS NEOPTOLEMUS	FR-361
UESS ABIA	FR-352	UESS PANDARUS	FR-362
UESS CARYSTUS	FR-353	UESS ORMENUS	FR-363
UESS DIA	FR-354	UESS ACAMUS	FR-364
UESS IASUS	FR-355	UESS NICIPPE	FR-365
UESS CERDO	FR-356	UESS CESTRINUS	FR-366
UESS TELEMACHUS	FR-357	UESS MENIPPE	FR-367
UESS MESSENE	FR-358	UESS DIOMEDE	FR-368
UESS TELEPHASSA	FR-359	UESS LAOTHOE	FR-369



## CHRYSE SUBCLASS

### AUTHORIZED CONSTRUCTION (CONTINUED)

UESS MACAON	FR-370	UESS LYCAON	FR-380
UESS OTHRYONEUS	FR-371	UESS DEMOPHON	FR-381
UESS LEPREUS	FR-372	UESS CELEUS	FR-382
UESS CAUCON	FR-373	UESS METANIRA	FR-383
UESS IODAME	FR-374	UESS BURRA	FR-384
UESS ITONUS	FR-375	UESS ION	FR-385
UESS AMPHICTYON	FR-376	UESS XUTHUS	FR-386
UESS ORESTHEUS	FR-377	UESS HELICE	FR-387
UESS DEUCALION	FR-378	UESS ATRAX	FR-388
UESS PYRRHA	FR-379		

### GENERAL INFORMATION

The Chryse subclass of the Durance first entered service with the United Earth Starfleet in 2158, during the Romulan War (2156-2160), and the last was decommissioned in 2163, in the second year of the Federation. Thirty-nine Chryses were procured, on a cost-cutting measure to acquire more logistical support for the rapidly maneuvering front-line forces. The savings were acquired by making the container pod concept permanent, installing a pressurized, shirt-sleeve environment inside a large cargo space. The standard rear hatch remains, and the issue with having less cargo capacity than of the Redstones was reversed, by including the warp repeaters. However, the overall consistent blocky shape resulted in consistent fuel costs, also reducing the range of this subclass (though still improved over that of the Redstones).

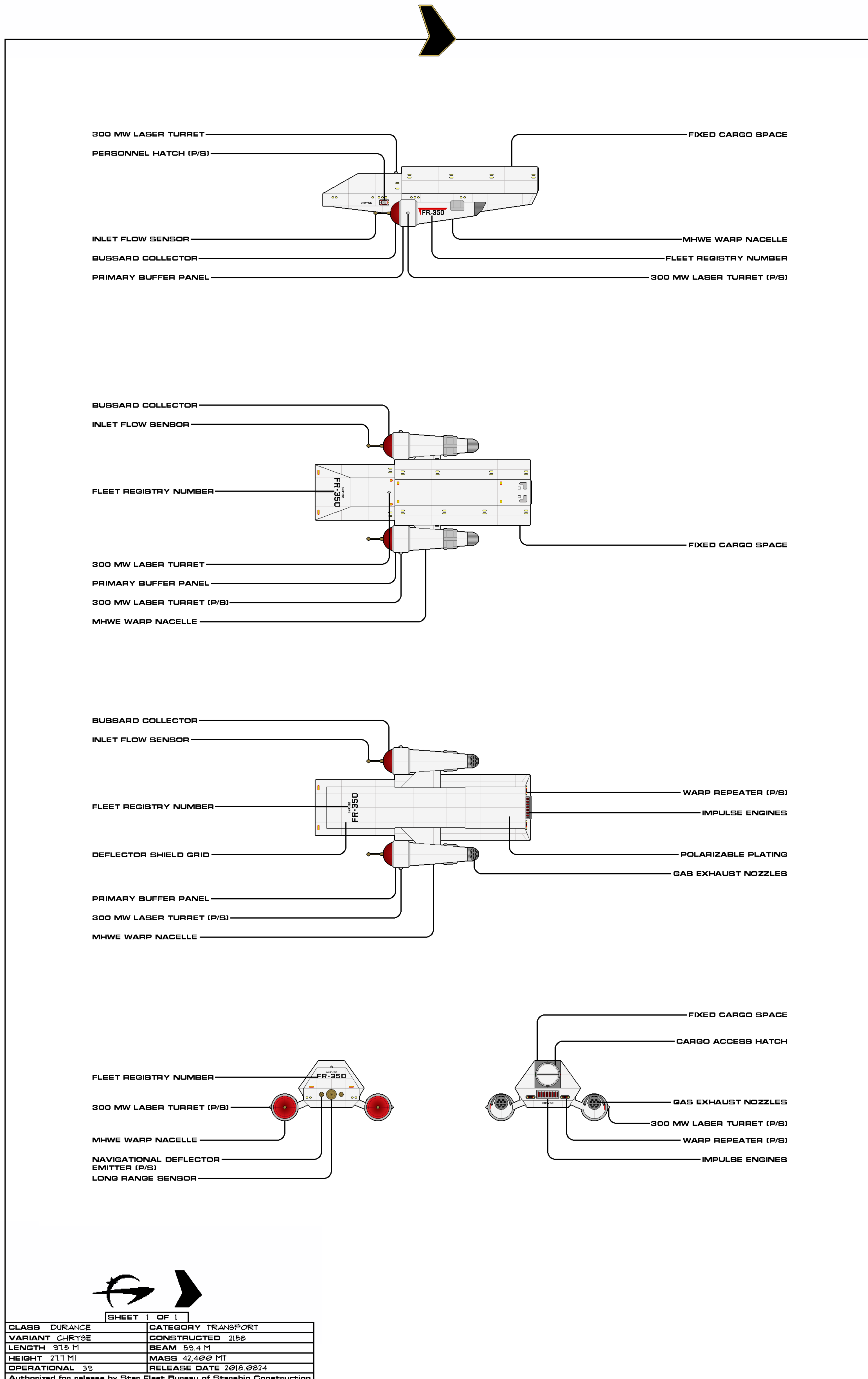

SHEET 1 OF 1

CLASS	DURANCE	CATEGORY	TRANSPORT
VARIANT	CHRYSE	CONSTRUCTED	2158
LENGTH	97.5 M	BEAM	59.4 M
HEIGHT	27.7 M	MASS	42,400 MT
OPERATIONAL	39	RELEASE DATE	2018.0824

Authorized for release by Star Fleet Bureau of Starship Construction



## CLASS TIMELINE

2129

The magnetic drag anchor failure of a ballistic barge results in a radiological hazard spill on the Kunlunshan plateau (and helps bring an end to that method of bulk delivery). Stuart class transports take part in the containment efforts.

A shipboard-capable workpod, the Class B1 (or IP-27), is introduced.

The Class B2 heavy transatmospheric pod enters service with the United Earth Stellar Navy and the United Earth Space Probe Agency.

Construction of the Durance class transports begins.

2130

The *Traité d'Unification* is signed by a majority of Earth's nations, establishing the new United Earth government.

Durance class transports enter service with the United Earth Stellar Navy (UESN).

The Vulcanian star empire leases a single smallish military ring drive vessel for testing and acclimatization purposes to the UESN, which is commissioned as the UES *Pirithous*.

2132

The UES *Carrizal* (Messier class) is detected by the Romulans as it passes through their system, though the vessel did not detect them due to technical problems. The Romulans are insulted by the perceived snub.

The first hostilities with the Romulan Star Empire occurs with the first offensive action taken against UES *Balboa*, when the Romulans detect it in their space. These initial clandestine Rihannsu attacks against Terran, Andorian, Tellarite and other shipping mark the first part of the conflict. This first phase of the conflict is characterized by a lack of coordinated UESF response, and continues until the Romulans deem it impossible to maintain the veil of secrecy any longer.

The last of the Durance class transports is completed.

2133

The United Earth government authorizes the formation of the United Earth Starfleet (UESF).

UESPA is folded within the UESF as its exploration arm. Ships are re-designated as UESS (for United Earth Space Ship).

2155

The Starfleet Corps of Engineers is considered to have been founded on the first day of the year by a team of engineers building Starbase 1.

Starbase 1 opens for operations.

The period of (only) clandestine attacks against non-Romulan shipping comes to an end

and the great offensive towards the heartspace of Earth and its allies begins.

The first punitive missions against the Romulans are mounted.

Attacks against Earth colonies are generally seen as the beginning of the official Romulan War.

The Romulans order Terrans out of the Algeron system (the location of Starbase 1) via subspace radio.

Starbase 1 is lost in a long-reaching Romulan attack.

The UESS *Goddard* (Edison class) is lost.

Earth, Andor, Vulcan, Tellar, Alpha Centauri and minor worlds (including Axanar and Kaferia) approve the first draft of an agreement for an alliance to be formed for trade, cultural exchange, and for mutual protection.

ECS *Kobayashi Maru* is lost to an apparent Klingon attack.

After almost 100 years in their initial location relatively near Earth (but without any contact with the planet), the spacebound Neyel colony encounter a spatial interphase rift that deposits them a thousand times farther from home--in the Small Magellanic Cloud, 200,000 lightyears from the Milky Way Galaxy.

Construction begins on the first of the Redstone subclass transports.

2156

The Berengarian counteroffensive denies the Romulans a swift and categorical victory. Seven *Daedalus* corvettes are lost during the operation.

The Andorian Empire formally withdraws from any conflict with the Romulans.

The first of six Mercury class scouts (in one year) is lost, presumably to Romulan action.

Admiral Rex Gunther, aboard his flagship, meets a solitary Romulan U-13 class cruiser near Eta Leonis VI. Instead of attacking, Admiral Gunther follows President Thorpe's instructions, opens known Romulan hailing frequencies, and warns the invading ship of his orders. Gunther gives the Romulan government six months to respond. Otherwise, it means war. Though the Romulan ship does not communicate, it is permitted to depart with the warning. This marks the sole meeting of Earth and Romulan warships without bloodshed on either side.

Since Admiral Gunther issued his warning, at least one allied warship has remained in the vicinity of Eta Leonis VI, awaiting a Romulan response. The UESS *Patton*, a brand-new Marshall class destroyer, is the ship on picket duty when three U-15 class cruisers close, in the Tri-Beta Sector advancing on the Rigel





## CLASS TIMELINE

star system. While decelerating, the Romulans open fire. The Patton's Captain Joseph Spadora makes one transmission before a Romulan cruiser fires a single guided missile. The torpedo hits the side of the Patton, totally disintegrating it. Spadora's message is received by other vessels in the area and relayed throughout the Federation. The Romulans' intentions are clear, and war is officially declared.

Earth attempts to persuade Andor to commit to a policy of mutual defense in the developing conflict against the Romulans, sending Admiral Palmieri onboard UESS Fomalhaut to open discussions. As a result, covert aid to Earth was granted, until they overtly rejoined the conflict in 2159.

UESS Kaiser (FC-87) lost to structural failure during Exercise Deep Vigil.

The third flight of Durance class transports, the Redstone subclass, enters service with the UE Starfleet.

On the most endangered shipping lanes, convoying is changed from constant escort to relay tactics.

The Durance class transports start receiving upgrades with laser turrets.

The SP-56 Class D1/SP-36 light atmospheric/spatial shuttles are fully removed from embarked shipboard service, upon their replacement onboard UESS Union.

2157

The last of six Mercury class scouts (in one year) is lost, presumably to Romulan action.

UESS Candace (S-5665) is damaged in an encounter with Romulan forces.

UESS Candace (S-5665) re-launches, is hijacked by stranded Romulans, recovered by the UESS Jackson (Cavalry class) and returned to drydock for repairs.

The Romulans penetrate the interplanetary security of the Sector 5B Mining Complex, destroying this important allied resource.

The Romulans conduct a starship suicide attack on the planet Vulcan.

The loss of six more Daedalus corvettes by the end of this year leads the class to be relegated to secondary roles shortly thereafter.

2158

The third flight of Durance class transports, the Chryse subclass, enters service with the UE Starfleet.

When Romulan forces are feared to reach Earth, frantic measures are taken to step up local defenses, and numerous outdated Djartannas are summoned to act as shields for the homeworld. Several engagements with

Romulan advance forces end in Romulan retreat, but Starfleet now has to assume the enemy has accurate knowledge of the inner worlds and their defenses.

The Ganges class destroyers are pressed to system defense service and begin to fight their battles under impulse power.

Tacticians surmise that almost a hundred of the forward colonies and outposts will have to be abandoned and new defense lines formed closer to Earth. As this will result in eventual defeat, an offensive strategy is researched.

UESS Candace (S-5665) is destroyed when the repair dock it was occupying is suicide-bombed by Romulan missile boats.

The lease on the UESS Pirithous is allowed to lapse, and the ship is returned to Vulcan.

Following severe battle damage, UESS Enterprise (NX-01, class lead) is recalled to Earth for an experimental overhaul.

2159

The period of the great offensive towards the heartspace of Earth and its allies by Romulan forces evolves into a war of attrition, as Earth and her allies begin offensive maneuvers.

One UESF battle group, consisting of the elderly Earthships Halsey, Gorshkov, and Yamamoto (all Messier class) and their escort destroyers and frigates, accidentally manage to locate a Romulan fleet stocking point at a distant unnamed star system in the Triangulum Australe region (in the Sierra sector). By wreaking havoc on dozens of dormant Romulan ships, the cruisers halt the Romulan offensive before it reaches the fringes of Earth colonization zones or the worlds of its neighbors and possible future allies. However, the self-destruction of the Romulan base cripples many of the human vessels. Later, the battle group is attacked several times, and only UESS Gorshkov and one frigate are capable of limping home. The war is far from over. A bitter point has been learned: the Romulans will acknowledge no other form of combat than a fight to death, be it as individuals or as a species.

The Andorians re-enter the Romulan War, providing Thofsin class cruisers to operate alongside Earth and Tellarite ships.

The lack of clear Romulan targets to strike is a cause of "desperation" for the UESF.

The final unmodified Durance class transport receives a weapons upgrade, for wartime defensive purposes.

Romulan light units blow up the orbital Spaceport Vega and retreat before the local Clark space tanks have a chance to concentrate their fire. The UESS Sapporo (Athens class) is destroyed in the attack.

Two Romulan cruisers are immobilized and prompted to self-destruct, a third destroyed



## CLASS TIMELINE

outright, and the invasion of Vega is averted, with the loss of four Clark class space tanks.

The decision is made to resume space tank production.

2260

Lalande 8 is saved by the UESS Tanganjika (FF-477) when it lures a suicidal Romulan auxiliary carrier into ramming an abandoned mining station instead of the mining colony.

Starbase Two comes on-line, with a large amount of medical expertise incorporated in the design.

UESS San Esteban (FF-491) is the only UESF ship lost with all hands in the final Romulan plunge at Alpha Omega B, taking with her two Romulan stormwings but unable to prevent the massacre of more than 20,000 people on the planetary settlement.

Construction on the Victory class battle cruiser prototype being built at Kaleb is halted, due to combat at nearby frontlines, while the hull is transferred to Andor.

A Doppler class scout reported the discovery of a frontline Romulan command center in the Cheron system.

Two days following the relay of the report of the frontline Romulan command center in the Cheron system, UESF Forward Observation Outpost 22 is destroyed.

Romulans attack Draylax, using a warp-speed kamikaze run, causing massive fires and volcanic eruptions all over the planet. Over a billion Draylaxians are killed, and more deaths are expected.

Starbase Three comes on-line.

The Battle of Gamma Hydra ends with a Terran win, though Admiral Larson is compelled to leave the UESS Kirov and UESS Kerry behind, along with 200 crew, in order to consolidate dilithium for the remaining three Achilles cruisers and two Enterprise explorers.

The Battle of Cheron marks the last major battle of the Romulan War. It is fought in Romulan space between two squadrons of allied ships and remnants of four Romulan groups. The Enterprise explorers draw the Romulan capital ships away, after which the seven Christopher light cruisers make their attack run within the 83 Leonis system. The battle ends inconclusively with neither side having any combat-capable ships remaining. This battle marks the allies' last opportunity to organize a fleet strong enough to reach the supposed location of the Romulan homeworld. It is considered a victory nevertheless, because the Romulans lose more than the allies, with the destruction of the frontline command center and the loss of the entire Romulan subspace communications network in sectors 23 through 28. The Andorian Imperial Guard strikes against Barradas and Draken nearly

simultaneously.

The Romulans send an offer for truce through subspace radio. Romulan ships everywhere disengage, withdraw several parsecs and wait for news of peace negotiations. These soon began under the leadership of Council Member Abraham Dannon.

The Romulans communicate with the Earth government and insist on additional terrestrial gains for the Romulan Star Empire. In exchange, they are willing to accept higher restrictions on Neutral Zone outposts. Dannon reluctantly makes many of the necessary concessions, and United Earth Council President Thorpe ratifies the completed Treaty of Peace. The treaty is transmitted to the Romulan Star Empire.

The UESS Olympia and UESS Coto (Poseidon class heavy cruisers) enter service just in time to take part in armistice celebrations.

The Romulan War allies and the Vulcans agree to form the United Federation of Planets in the following year.

The last of the 38 Redstone subclass transports is completed.

2161

UESS Enterprise (NX-01) of Enterprise explorer class is decommissioned (never having served in the UFP Star Fleet), restored to her original design internally and externally, and preserved as a museum specimen. The other four surviving members of the class soon follow Enterprise into retirement.

The Imperial Senate of the Romulan Star Empire broadcasts its ratification of the Treaty of Peace on all subspace frequencies. The message is picked up by allied starships along the border, and the treaty terms go into immediate effect. After 28 years of piratical attacks, open warfare, and staggering losses on both sides, the Romulan War is finally over.

UESS Cavalier (ND-626, Cavalry class) is shot to pieces well after the official declaration of ceasefire and limps to a crash landing onto an unexplored, barely M-class world.

The Articles of the Federation are signed by United Earth, the Confederacy of Vulcan, the Andorian Empire, Tellar, and Alpha Centauri in San Francisco, officially establishing the existence of the United Federation of Planets.

The UFP Star Fleet is founded, as well as is the Committee for Star Fleet. All vessels transferred to the organization are re-designated as USS (for United Star Ship).

The United Earth Starfleet changes its official organizational name to Earth Fleet.

Vulcan indicates that it will not provide any of its warp 7-capable capital vessels to either the Defense or Exploration Commands, as a means to promote a de-escalation policy. Earth Fleet, in



## CLASS TIMELINE

response, agrees to transfer the Columbia class Endeavor to UESPA for exploration purposes.

Star Fleet Academy is established in San Francisco.

The Ganges class destroyers are pressed into patrolling the newly-established Neutral Zone, while a few others patrol intra-Federation spacelanes or provided system defense.

Vulcan Ambassador Solkar is replaced by Ambassador T'Jan, marking a transition to an era of openness and equality in Earth-Vulcan relations.

The light cruiser Piranha and the transport vessel Roy Malcolm are dispatched to the Gamma Hydra system to rescue the stranded UESS Kirov and UESS Kerry (both Achilles class cruisers), but are unable to locate the vessels or their crews.

The war-weary UESS Emden (Helena class cruiser) is decommissioned and scrapped immediately following the war.

The Vulcan High Command begins pulling back its deep space patrol fleet.

2162

The surviving crew of UESS Cavalier (ND-626, Cavalry class), is found alive and in good health by USS Lorelei (Helena class). Their recovery is a long-awaited positive media event in the middle of the postwar atmosphere of disillusionment, ambiguity and anxiety.

The two Aberdeen subclass escort cruisers are decommissioned.

The first class of Star Fleet Academy convenes amongst the under-construction campus in San Francisco.

A conflict erupts with the Tarn, when a Star Fleet vessel is attacked and over 200 crew are killed.

Work progresses on shield/warp field integration, at first on the Triton fleet, then on the new human flagship, USS Endeavour (NCC-06, Columbia class).

The USS Verdun and USS Constantine, both Messier class, are pressed to duty against the Tarn. Both disappear: the Constantine without a trace and the Verdun until 2366.

The last Messier to be retired, USS Braxton (CA-195), is on her way to be preserved in the recently founded Star Fleet Museum when her warp drive system creates a catastrophic asymmetry and tears the ship into pieces. The skeleton crew of fifteen is killed instantly.

Earth Councillor Dannon is assassinated while making a pacifist speech on Federation grounds in San Francisco.

The newly upgraded USS Endeavour (NCC-06, Columbia class) heads out on a sweeping mission of frontier diplomacy in the Tandar-Rigel flank of the nascent Federation.

The last of the 39 Chryse subclass transports are completed.

2163

All of the Durance class transports (and related subclasses) are retired.

The USS Aurora, USS Mistral and USS Rio Negro (all Helena class cruisers) are deployed to the Tarn conflict (and lost).

The Merchant class heavy transport is introduced by Vickers for commercial use on the fully re-opened Federation cargo routes.

The Vulcan company Panastris unveils the Gadshen ('aurora') liaison craft.

### Note regarding the use of ship prefixes:

The Federation's Star Fleet was preceded by the military forces of its founding members. For Earth, those agencies were the United Earth Stellar Navy (UESN), from 2069 into 2133, and the United Earth Starfleet (UESF), from 2133 into 2161. While additional details of these predecessors will be explored in a later release, it should be understood that the ship prefixes of vessels that served with both forces changed to match their governing authority at the time of the respective formation. For the Stellar Navy, that ship prefix was UES, while it was UESS for Earth's Starfleet (both prefixes defined in the Glossary).

Additionally, not all military vessels were transferred by the founding members to the Federation Star Fleet. Those that were received the USS ship prefix, while those that stayed with the newly-renamed Earth Fleet retained UESS before their proper names. Therefore, any reference to vessels with the UESS prefix following 2161 indicate they fall under the Earth Fleet registry.



# STARSHIP COMPARISON GUIDE

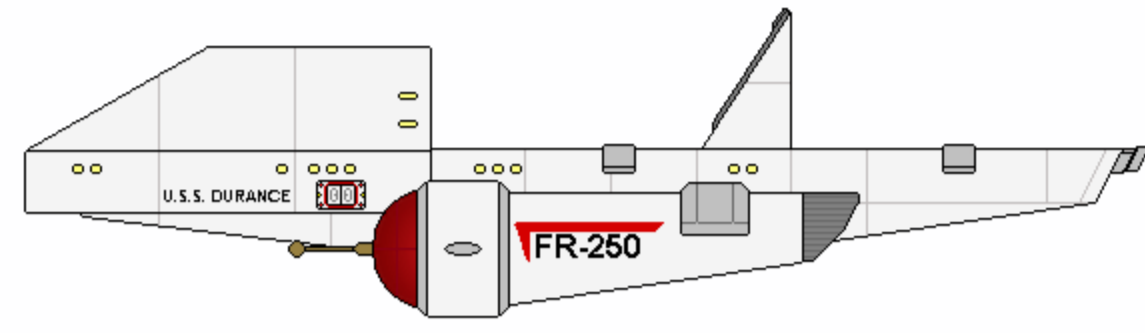

DURANCE  
TRANSPORT (CONFIG 1)

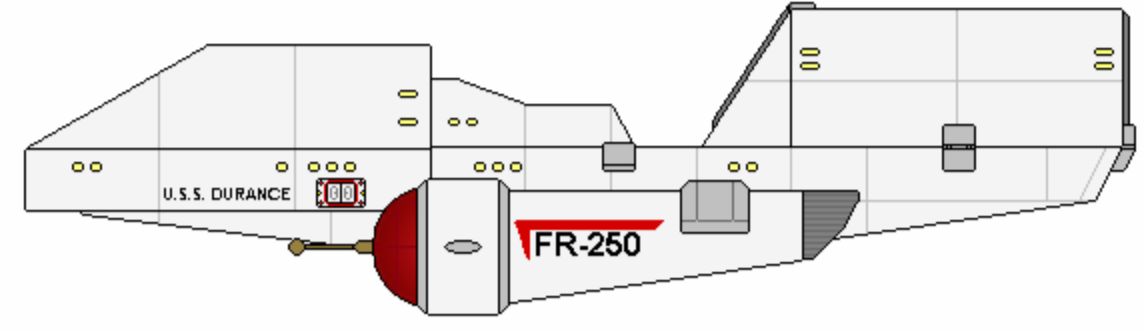

DURANCE  
TRANSPORT (CONFIG 2)

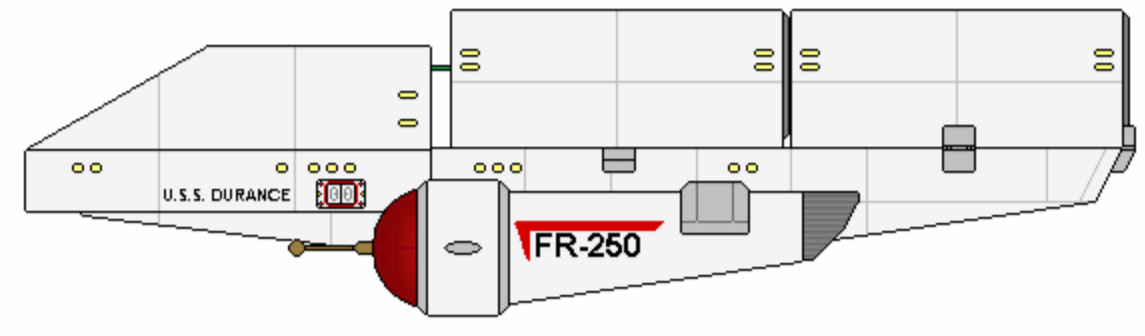

DURANCE  
TRANSPORT (CONFIG 3)

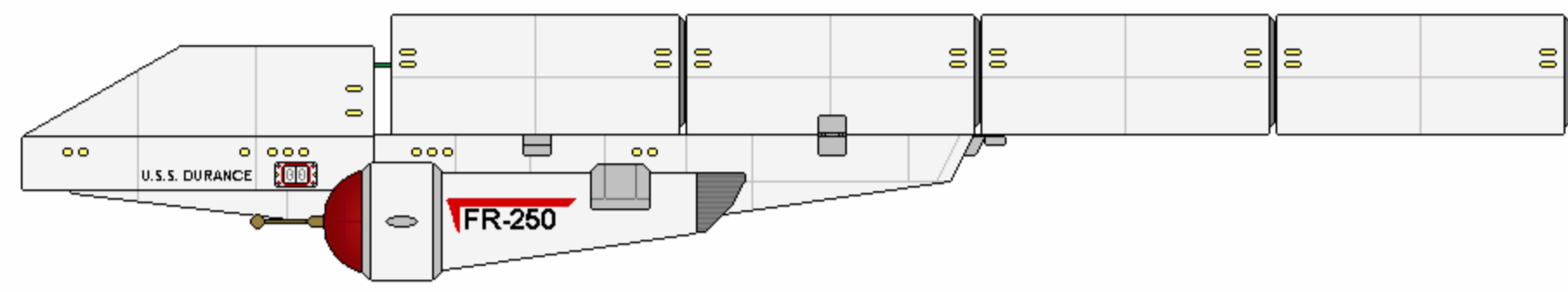

DURANCE  
TRANSPORT (CONFIG 4)

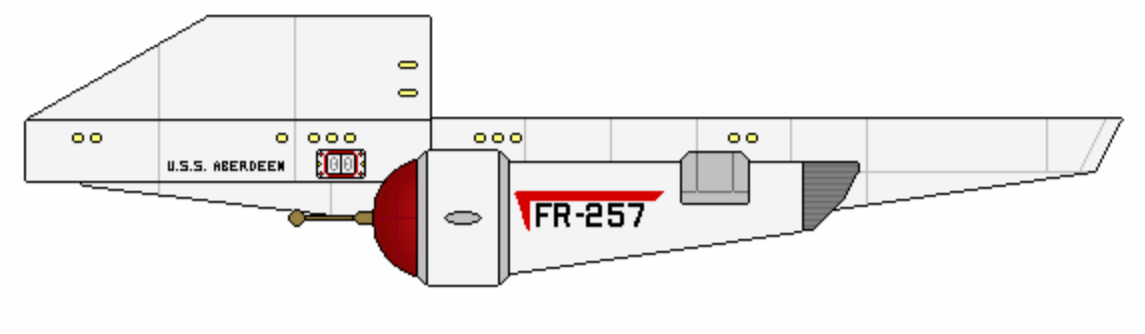

ABERDEEN  
ESCORT CRUISER

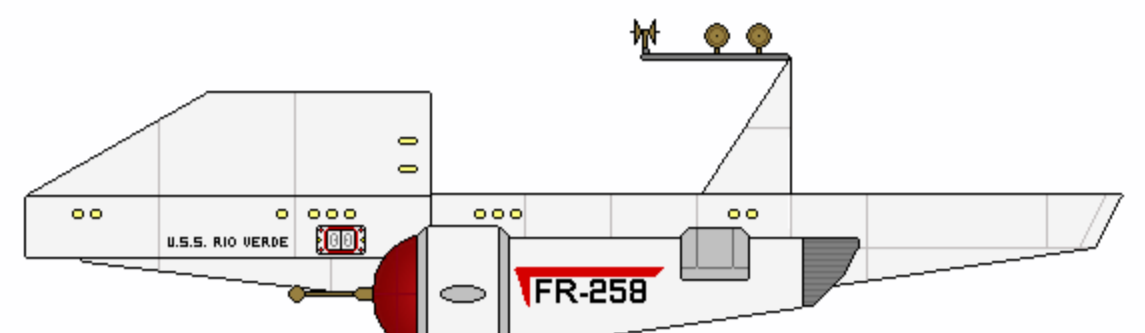

RIO VERDE  
SURVEY VESSEL

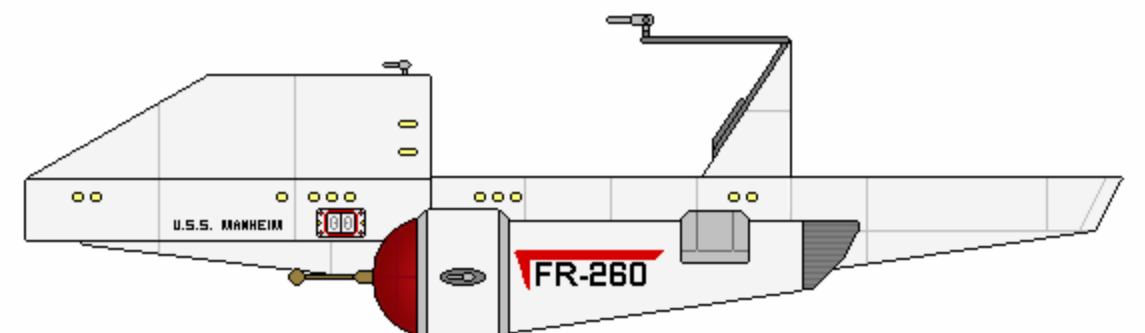

MANHEIM  
DESTROYER

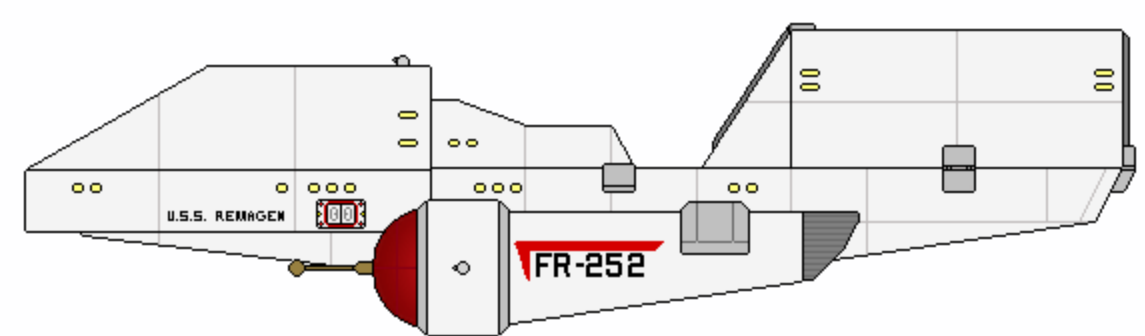

DURANCE  
WARTIME FIT (CONFIG 2)

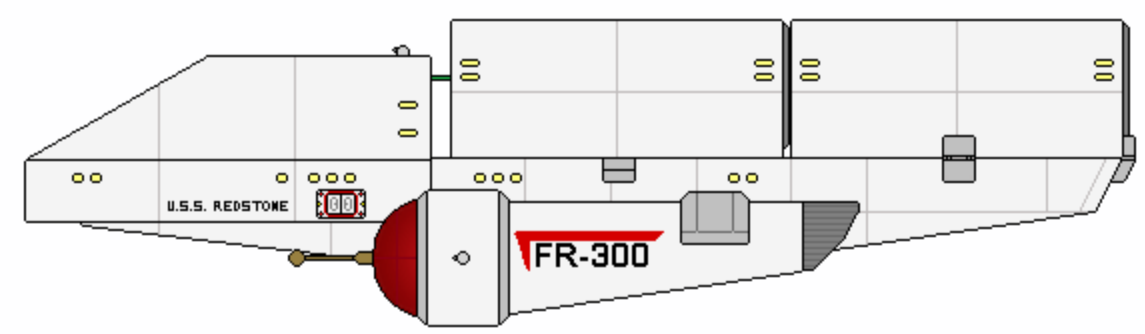

REDSTONE  
TRANSPORT

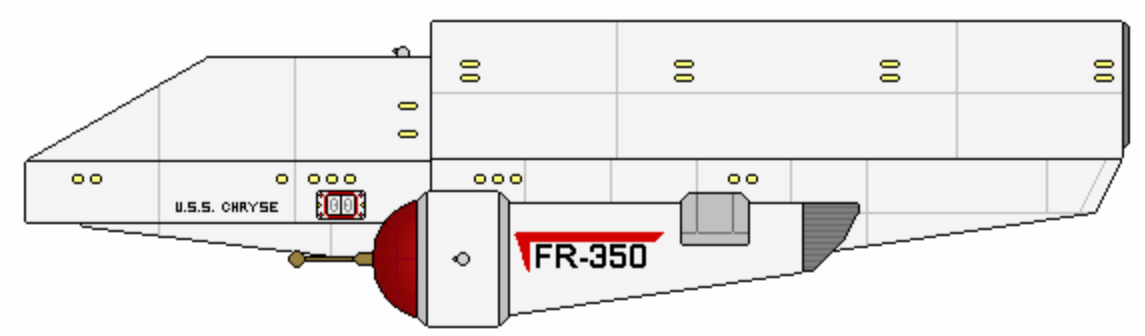

CHRYSE  
TRANSPORT



## GLOSSARY

**Array:** Generally, a combination of identical sensors, weapons, or other equipment operating in conjunction.

**Barge:** one of several differing types of vessels, including 1) a low-warp bulk carrier designed to transport unpackaged bulk cargo; 2) an orbital-to-atmosphere combat lander, usually heavily armored and lightly armed, to transport large troop formations into defended surface areas.

**C/P/S:** Centerline/Port/Starboard (see P/S).

**Class:** a production run of vessels all to identical (or nearly identical) standards. Ex: the Constitution class

**Corvette:** Small warp-capable ship dedicated to local patrol, law enforcement and community service missions. Sometimes landing-capable, not dependent on starbase facilities for support.

**Cruiser:** A medium multi-purpose starship. The largest exploration vessels until the early 24th century, when relegated to other duties with the introduction of large Explorer starships.

**Deep space:** The region near or beyond the recognized borders of the Federation, often uncharted in any considerable detail.

**Destroyer:** A medium offense starship intended for destroying enemy capital ships and installations, as well as conducting fleet escorts.

**ECS:** Earth Cargo Ship, a prefix for vessels flagged under the governing authority of the Earth Cargo Service.

**ELRS:** Extreme Long Range Sensor

**Flight:** A modification to a class of ship intended to be incorporated by most or all members of that class.

**Flitter:** an extremely low-altitude planetary personnel and freight vehicle, utilizing anti-grav hover equipment. Larger vehicles might resemble wheel-less trucks, with the smallest analogues to one- or two-person motorcycles.

**Frigate:** Until the late 22nd century, a dedicated medium defense and escort starship, larger than corvette but smaller than destroyer, often capable of trans-atmospheric operations. In the 23rd century and into the early 24th century, often used to designate defense and escort starships ranging from small patrol and escort ships typically lacking torpedo armament to versatile multipurpose ships similar to light cruisers.

**FTL:** abbreviation for Faster Than Light.

**GW:** GigaWatt

**Hopper:** a small vehicle designed for atmospheric flight. While some may have limited aerospace capabilities, they are generally utilized for intra- and intercity transport of personnel.

**ISA:** International Space Agency. Formed by the NUN in 2018 in an effort to coordinate international space exploration missions. Succeeded by both the UESPA and UESN in 2067 and 2069, respectively.

**Ishakawa-Dell Barrier:** The exponential growth in the power required by early warp nacelles as FTL speeds approached warp factor 6 (on the OCU scale).

**Laser:** Typically, a secondary weapon on early space vessels. Current shielding technology has largely negated the threat posed by the coherent electromagnetic beam.

**M:** Meters

**M/AM:** Matter/Antimatter

**MT:** Metric Tons

**Navigation Light:** Yellow in color; these lights are generally located on or near major points of superstructure of a space vessel. They often provide low-emission positioning signals for specific locations on and within the vessel for the purposes of proximity maneuvering by another vessel and relative destination positions for transporters. Not to be confused with red or green running lights.

**NCC:** Letter prefix in UFP Starfleet vessel registries, anecdotally said to come from the term Naval Construction Contract. Current usage has letter N signifying UFP registry, and CC signifying active Star Fleet forces.

**Nearspace:** The region of the Federation considered to be internal, fully charted, and uncontested.

**NUN:** New United Nations. Formed in 2011, first dissolved in 2053 (during the Third World War), re-formed in 2065 (two years following First Contact), then finally dissolved in 2079. Authorized the formation of the ISA (2018), UESPA (2067), UEDP and UESN (both 2069). Succeeded by the UEDP



## GLOSSARY (CONTINUED)

OCU: Original Cochrane Units, representing the original warp scale, where the warp factor cubed was the velocity in c, the speed of light.

Operational Standard: the description and designation for a previous testbed or prototype vessel that has been made operational, though not necessarily to the standards of the official class. Ex: USS Constellation (operational standard)

P/S: Port/Starboard; left & right side, respectively, in naval parlance.

Particle Cannon: A primary or secondary weapon on some early space vessels, though generally replaced by phaser technology. The weapon accelerated charged or neutral matter (or antimatter) particles to relativistic speeds. Also commonly known as phase cannons.

Phase Cannon: (see Particle Cannon)

Phaser: A directed-energy/particle weapon in common use aboard Star Fleet vessels, as well as other UFP and foreign fleets. Based upon rapid radion effect, it generates a wide-band particle beam utilizing both electromagnetic and subspace components.

Plasma Cannon: A projectile weapon in common use aboard early space vessels. A sublight weapon, the cannon generates, contains, and directs the release of ionized matter. The weapon is often complemented by particle and/or laser weapon systems.

Prototype: a vessel constructed (or modified) to perform tests and trials of a potential new class (or subclass) of ship.

Running Light: Red (port/left) and green (starboard/right) lights traditionally denoting the observed side of a water vessel under low light conditions. Utilized for similar purposes by space vessels of the UFP though generally for rapid orientation by the pilots/helms of other vessels maneuvering in close proximity. Not to be confused with yellow navigation lights.

SCE: (see Star Fleet Corps of Engineers)

Scout: A small to medium, fast research and/or reconnaissance space vessel, equipped with extensive sensor and research equipment. Though protected by defensive energy weapons, most substitute probe launchers for torpedoes.

Series: a succession of vessels all deriving from one standard, comprised of the original class, subclasses, flights, and types. Ex: the Constitution series

Shuttle: An auxiliary craft carried by larger vessels for orbit-to-ground transportation or detached operations. Also used for starbase liaison duties.

Shuttlepod: Very small auxiliary craft used for ship-to-ship or orbit-to-ground transportation, free-space maintenance, and repair work, and detached operations of a very limited nature. Usually not equipped with a warp drive.

Star Fleet: The primary exploration and defense organization of the UFP. Formed in 2161 to protect the integrity of the Federation and the safety of its members and to expand the knowledge of the member cultures.

Star Fleet Corps of Engineers: the special construction, maintenance, repair, and public engineering management agency (an echelon of Star Fleet Engineering) for both Star Fleet and the Federation. The SCE is often tasked with building and maintaining facilities both standard and exotic, as well as providing rapid response to engineering problems that occur far from Federation resources.

Starfleet: Short-hand name for the United Earth Starfleet (UESF), the primary exploration and defense organization of United Earth 2033-2161. Not to be confused with the UFP Star Fleet. Renamed Earth Fleet upon the formation of the United Federation of Planets.

STL: abbreviation for Slower Than Light.

Subclass: A significant variant of a given class of ship, usually newbuilds, though sometimes including important modifications to existing ships, that are not intended to replace the existing ships of the original class. Often named for the first ship to reach that final intended production standard.

Tender: An auxiliary vessel specifically designed for deep space replenishment and support of starships and other vessels. While often equipped with a tractor device, the inability to efficiently tow another vessel in warp distinguishes the tender from a tug.

Testbed: a vessel constructed (or modified) as a platform to test new technologies, with the vessel not necessarily transitioning to an operational status.

TNG: Terrance-Nelorr Graduated scale where upon each full warp factor is achieved when a certain number of cochranes were met in output, resulting in more efficient engine plateaus. In this scale, Warp 10 is unattainable.

Torpedo: The general designation for warp-capable guided projectile weapons, in contrast to sublight-only guided missiles.



## GLOSSARY (CONTINUED)

**Transport:** A Starship or other vessel dedicated to transporting passengers or cargo. They range in size from small two- or three-crew ships to huge starships and freighters.

**Transwarp Drive:** The common name for drive systems capable of higher speeds and efficiencies than the warp drive currently in use throughout the Federation. Promising venues of research include deep subspace immersion, new power regulation methods, dimensional rift techniques, and time manipulation. No practical drives of these types are yet available at this time.

**Tug:** 1) A warp-powered ship specifically designed to extend her warp field around objects that can thereafter be towed at warp speeds. Primarily used for the carriage of transport pods and towing of disabled starships or other equipment lacking appropriate motive capabilities. 2) A craft designed to propel ships or equipment lacking motive power about a limited area of operation, such as a space dock or construction site. May also refer to such a vessel intended to assist ships maneuvering within and in the vicinity of docking facilities.

**TW:** TerraWatt

**Tyme Barrier:** The exponential growth in the power required by early warp nacelles as FTL speeds approached warp factor 7 (on the OCU scale).

**Type:** a variant to a class, subclass, or flight that is extremely limited in numbers and not intended to supplant the origin category. Oftentimes used to explore potential variations for future upgrades. Ex: the Bonhomme Richard subclass (Type 2)

**UEDP:** United Earth Defense Pact. Formed by the NUN in 2069 to put the "Earth's ascendancy and safety ahead of national goals". Tasked with the combined command and control of the planet's various armed forces, it became the de facto world government upon the NUN's second dissolution in 2079, until superseded by the United Earth government in 2130.

**UES:** United Earth Ship. Ship prefix for the names of vessels of the UESN.

**UESF:** (see Starfleet)

**UESN:** United Earth Stellar Navy. Predecessor to the UESF. Formed under the authority of the United Earth Defense Pact in 2069.

**UESPA:** United Earth Space Probe Agency. Formed by the NUN in 2067, relieving the ISA of the coordination and development of human presence in interstellar space. Re-purposed as the exploration arm of the NUN in 2069.

**UESS:** United Earth Space Ship. Ship prefix for the names of vessels of the United Earth Starfleet.

**UFP:** United Federation of Planets. Formed in 2161 by a coalition of United Earth, the Andorian Empire, Tellar, Alpha Centauri, and the Confederacy of Vulcan, following the Romulan War.

**UFP SF:** (see Star Fleet)

**USS:** UFP Star Fleet Starship. Ship prefix for the names of Star Fleet vessels, emblazoned on ship hulls (along with the ship's registry number). Commonly abbreviated as "United Starship" in verbal communication, although the expressions "United Spaceship" and "Federation Starship" are also frequently used.

**Work Pod:** The general name for manned, sub-impulse craft used for construction, maintenance, repair, and other service tasks in space. A variety of external tools and modules are attached to the work pods to facilitate a multitude of tasks.



Delta Dynamics appreciates the sponsorship of the following:



Tigan Pergium Mining



Federation News Network (FNN)



Earth Sciences Institute



Plexicorp



The Anbo-iyutsu Society



Utopia Planitia Shipyards



Vulcan Science Academy



Starfleet Academy

...and Members like you.





THE FOLLOWING ARE OTHER STARSHIP RECOGNITION MANUALS  
PUBLISHED BY DELTA DYNAMICS:

## **REPORTS**

- BONAVENTURE survey cruiser
- BONAVENTURE dilithium power testbed
- BURKE frigates
- CONSTITUTION heavy cruisers
- DURANCE cargo tugs
- HORIZON heavy cruisers
- SYRACUSE destroyers
- TRENT destroyers

