

# AMBASSADOR CLASS HEAVY CRUISER

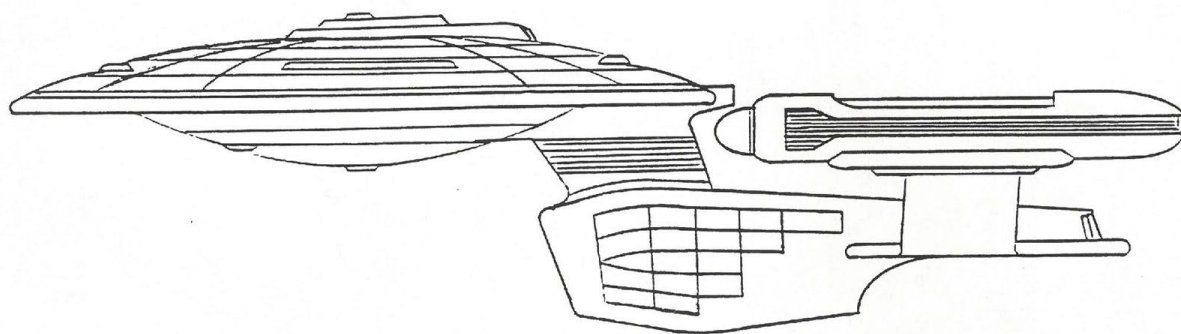

**GENERAL PLANS**

SIX 11" X 17" SHEETS

AND A GAMING DATA SHEET

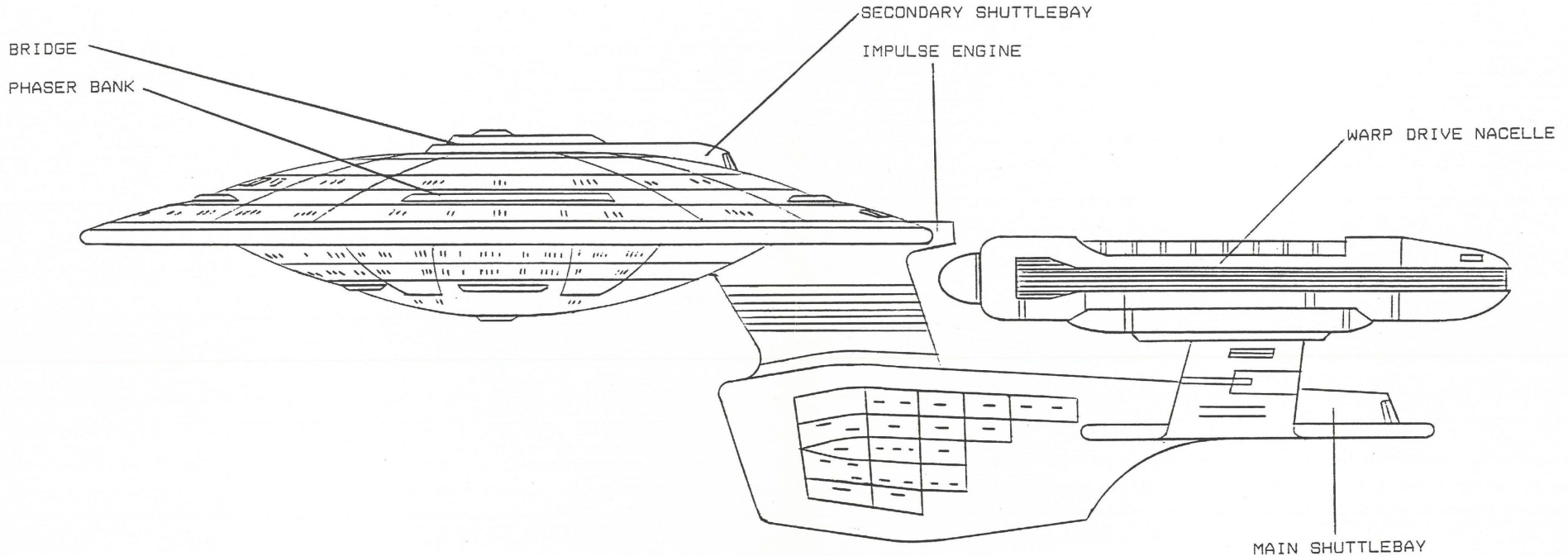

**AMBASSADOR CLASS**  
**HEAVY CRUISER**

COMPILATION: Confederated Rimward  
Planets INFOnet

SCALE 1:1750

DRAWN BY:

*Stephen Cy*

(c) 1992 STEPHEN ARENBURG

Not intended to infringe on any  
of Paramount Studios Trademarks

MODEL 27001 : HEAVY CRUISER

SHT 1 OF 6: OUTBOARD PROFILE

# AMBASSADOR CLASS

## HEAVY CRUISER

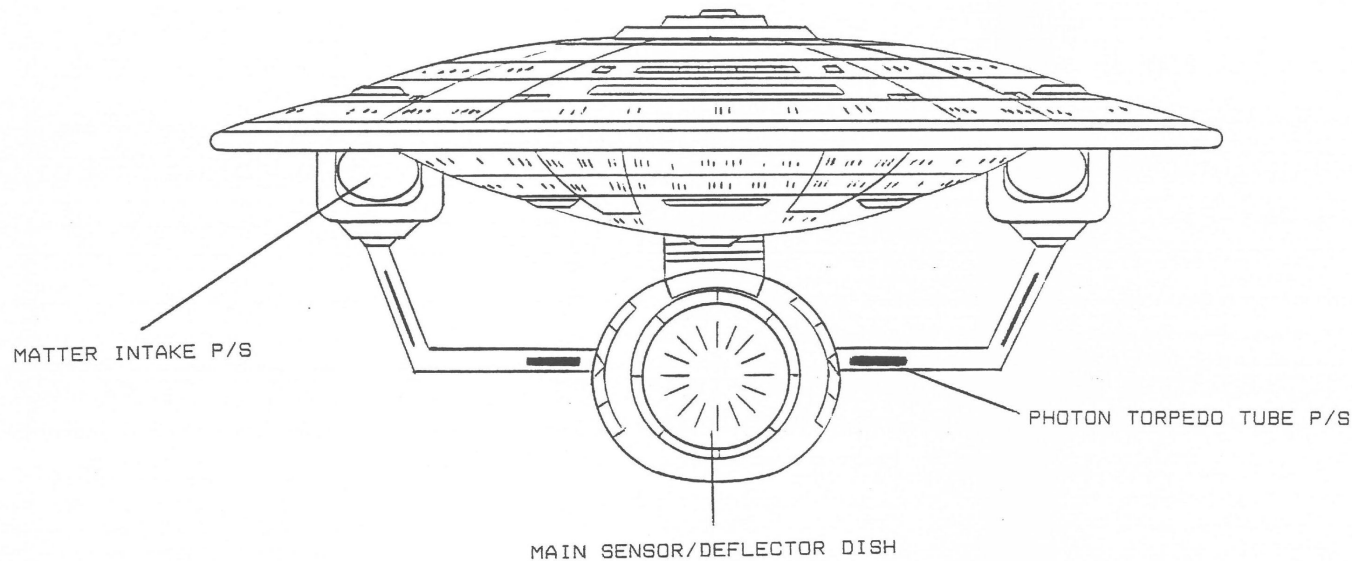

The Ambassador Class was designed as research and exploration cruiser for Starfleet's Galaxy Exploration Division.

These vessels are equipped with first generation transwarp drive, and a new, compact impulse engine. An auxiliary power reactor, and emergency battery stations are also standard. This class is the first to feature a quick-detach primary hull, which is capable of routine connection and disconnection of the saucer section.

The ship features the first installment of multiple phasers fired through a single collimator/emitter. A pair of standard phaser banks is also carried as a secondary battery. Three multi-firing photon torpedo tubes round out the armament. The two forward firing tubes can fire four torpedoes simultaneously (each), while the rear tube can fire six.

The ship features type 4 deflector shields and an integral-warp-field energized hull as the primary defence systems. A comprehensive sensor suite rounds out the system.

These vessels still serve in their primary mission role.

# AMBASSADOR CLASS

## HEAVY CRUISER

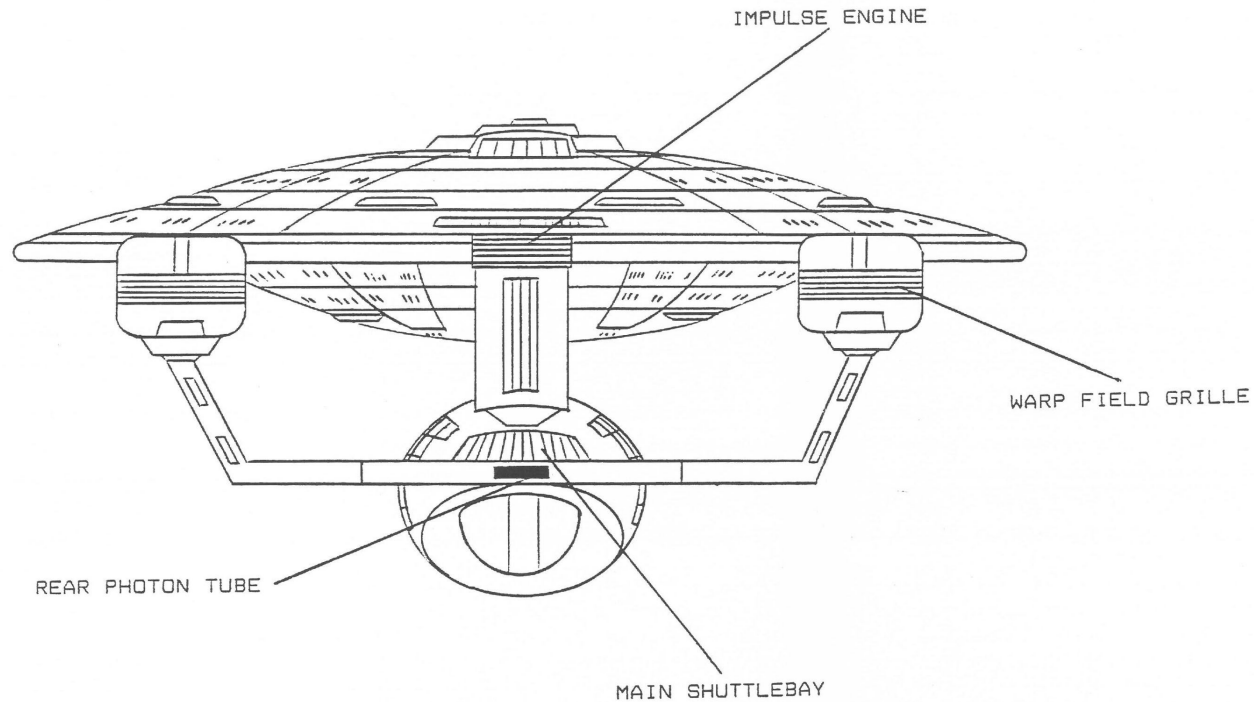

### PARTICULARS

STD. MASS	434 000 TONS
LENGTH O.A.	548 m
WIDTH O.A.	326 m
HEIGHT O.A.	157 m
WARP DRIVES	2 FT-551 Mk. I
YIELD	400 GW
IMPULSE ENGINE	PLASMA-TEK 4
YIELD	60 GW
SPEED	
CRUISING	TRANSWARP 6
EMERGENCY	TRANSWARP 8
ENDURANCE	12 YEARS
CREW	695
PASSENGERS	105
TRANSPORTERS	
STD. 6 PERSON	6
EMG. 18 PERSON	6
CARGO	2
PHASERS	
MAIN COLLIMATOR BARS	6
SECONDARY	2 BANKS/2 EACH
TORPEDOES	3 TUBES
SHIELDS	RATED 225 GWA
COMBAT RATING	2235/1268

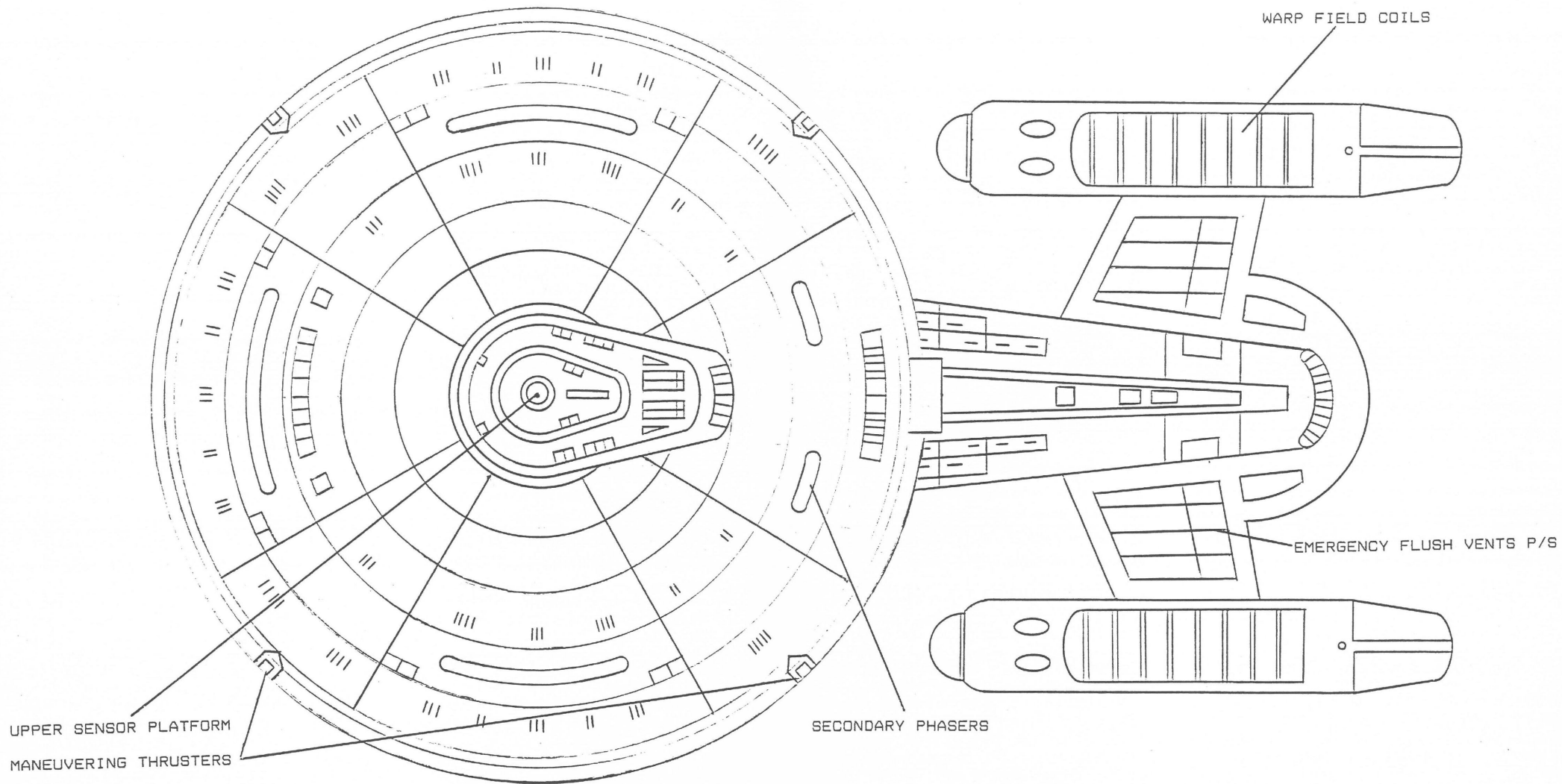

# AMBASSADOR CLASS HEAVY CRUISER

TOP PLAN

SHEET 4 OF 6

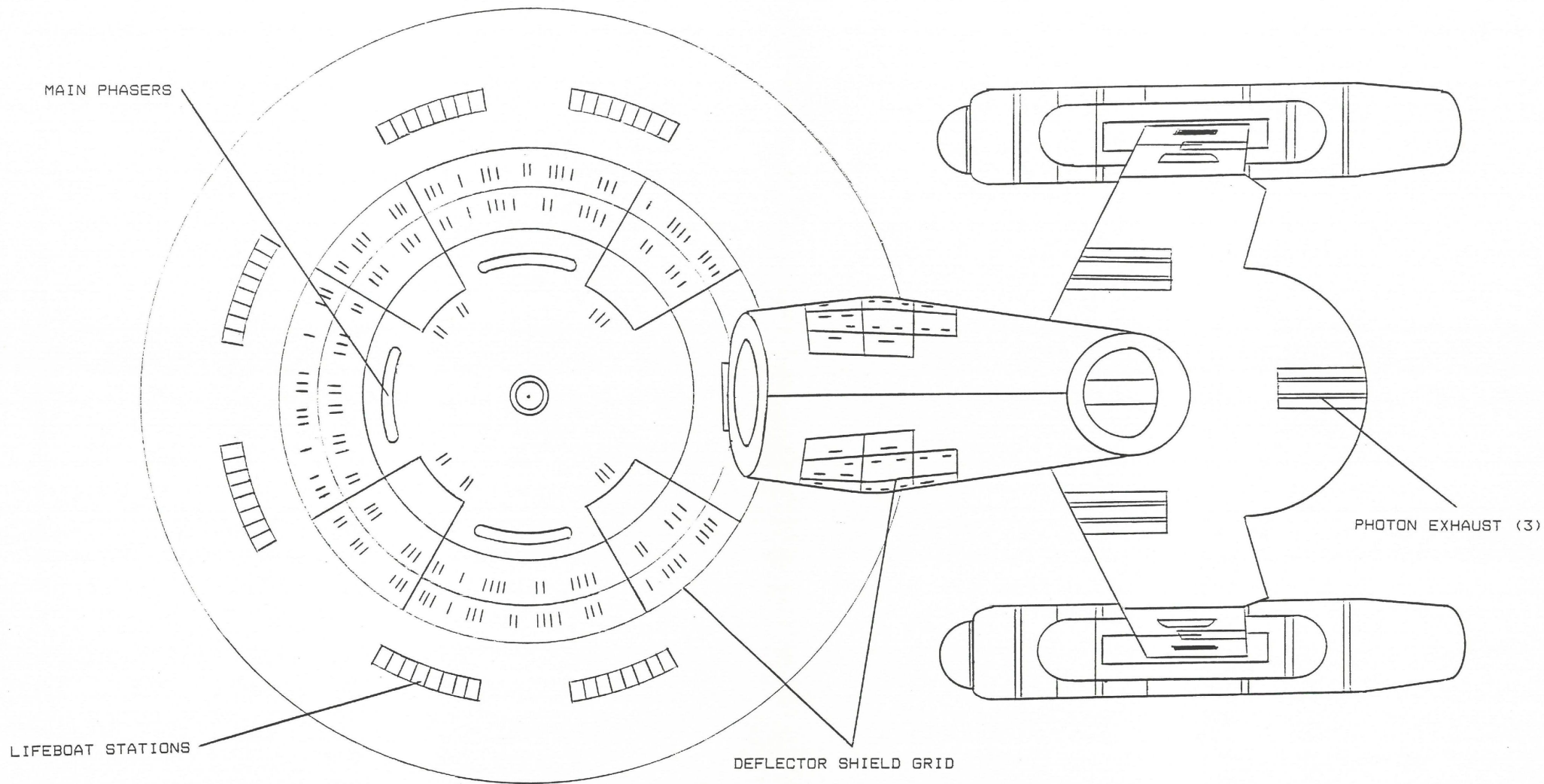

# AMBASSADOR CLASS HEAVY CRUISER

BOTTOM PLAN

SHEET 5 OF 6

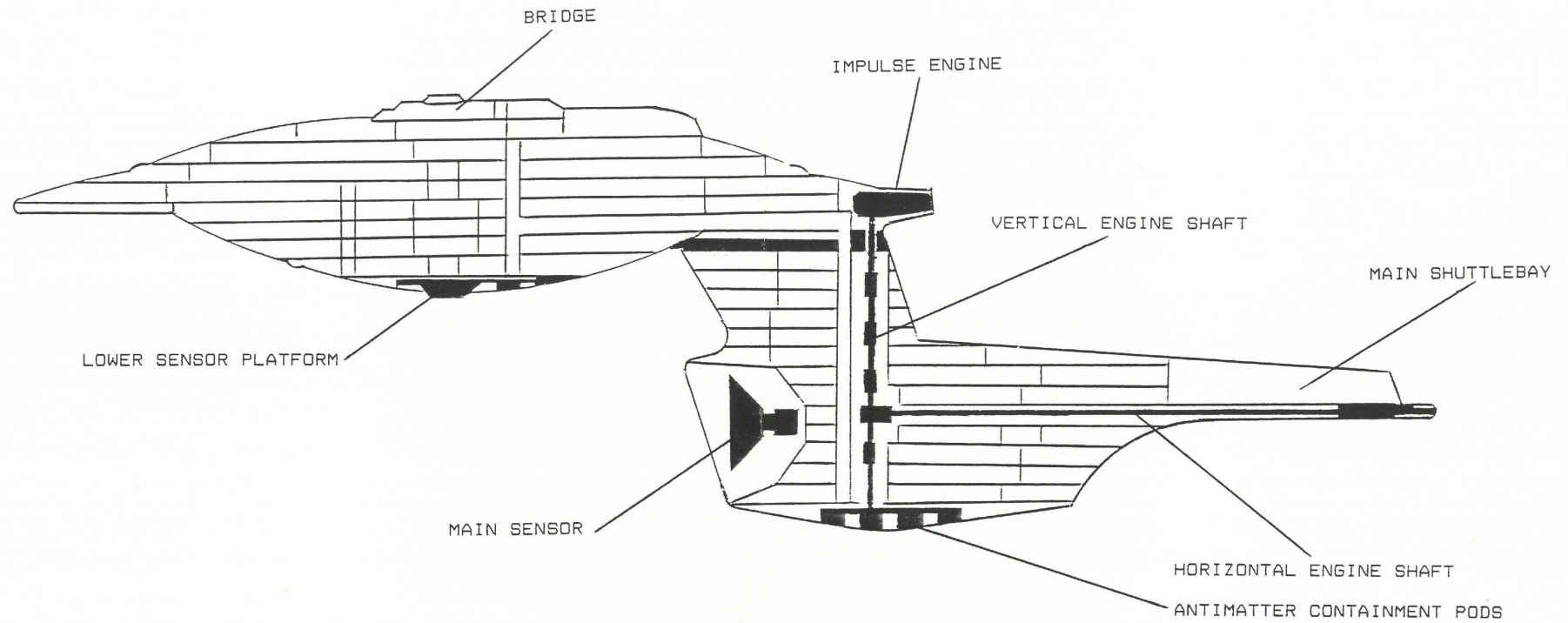

# AMBASSADOR CLASS HEAVY CRUISER

INBOARD PROFILE

SHEET 6 OF 6

